

**8007/8019/8002**

---

**SINGER**

## IMPORTANT SAFETY INSTRUCTIONS

When using this machine, basic safety precautions should always be followed including the following:

Read all instructions before using this machine.

### **DANGER**—To reduce the risk of electric shock:

- The machine should never be left unattended when plugged in. Always unplug the machine from the electric outlet immediately after using and before cleaning.
- Always unplug before relamping. Replace bulb with the same type rated 15 watts. Be sure to replace the face plate which covers the light bulb before operating the machine.

### **WARNING**— To reduce the risk of burns, fire, electric shock or injury to persons:

- Be sure that the electrical voltage of the socket outlet (wall receptacle) is the same as the rated voltage of the motor.
- Use this machine only for its intended use as described in this Operator's Guide. Use only attachments recommended by the manufacturer as contained in the Operator's Guide.
- To disconnect, turn all controls to the off ("0") position, then remove plug from outlet.
- Disconnect the power-line plug from the socket outlet or switch the machine off when making any adjustments in the needle area, such as threading needle, changing needle, changing throat plate or changing presser foot, etc.
- Always unplug the machine from the electrical outlet when removing covers, lubricating, or when making any other user servicing adjustments mentioned in the Operator's Guide.
- Do not attempt to adjust the motor belt. Contact your nearest Service Center should any adjustment be required.
- Do not unplug by pulling on cord. To unplug, grasp the plug, not the cord.
- Handle the foot controller with care and avoid dropping it on the floor. Be sure not to place anything on top of it.
- Always use the proper throat plate. The wrong plate can cause the needle to break.
- Do not use bent needles.
- When sewing, keep fingers away from all moving parts. Special care is required around the sewing machine needle.
- Do not pull or push fabric while stitching. It may deflect the needle causing it to break.
- Before removing the bobbin case, remove plug from the socket outlet.
- For double insulated machines, when servicing use only identical replacement parts. See instructions for Servicing of Double-Insulated Appliances.

- Never operate the machine if it has a damaged cord or plug, if it is not working properly, if it has been dropped or damaged, or dropped into the water. Return the machine to the nearest authorized dealer or Service Center for examination, repair, electrical, or mechanical adjustment.
- Never operate the machine with any air openings blocked. Keep ventilation openings of the machine and foot controller free from the accumulation of lint, dust, and loose cloth.
- Never drop or insert any object into any opening.
- Do not use outdoors.
- Do not operate where aerosol (spray) products are being used or where oxygen is being administered.
- Do not allow to be used as a toy. Close attention is necessary when the machine is used by or near children.
- **SERVICING OF DOUBLE-INSULATED PRODUCTS.** In a double-insulated product, two systems of insulation are provided instead of grounding. No grounding means is provided on a double-insulated product, nor should a means for grounding be added to the product. Servicing of a double-insulated product requires extreme care and knowledge of the system, and should be done only by qualified service personnel. Replacement parts for a double-insulated product must be identical to those parts in the product. A double-insulated product is marked with the words "DOUBLE INSULATION" or "DOUBLE INSULATED."

### SAVE THESE INSTRUCTIONS

Servicing should be performed by an authorized service representative.

This product is intended for household use.

### FOR EUROPEAN AND SIMILAR TERRITORIES:

This product is suppressed for radio and television interference with the International Electrotechnical Commission requirements of the CISPR.

Machines for Great Britain and some other countries having similar wiring standards are shipped from the factory without a plug for connection to the mains. The wires in this mains lead are coloured in accordance with the following code.

Blue : neutral (N)                      Brown : live (L)

As the colours of the wires in the mains lead of this appliance may not correspond with the coloured markings identifying the terminals in your plug, proceed as follows:

The wire which is coloured blue must be connected to the terminal which is marked with the letter N or coloured black. The wire which is coloured brown must be connected to the terminal which is marked with letter L or coloured red. If a 13 Amp. (BS1363) plug is used, a 3 Amp. fuse must be fitted, or if any other type of plug is used, a 5 Amp. fuse must be fitted either in the plug or adaptor or at the distribution board. Neither cord is to be connected to the earth terminal of a three-pin plug.

# Index

<b>1. Getting to Know Your Machine</b> .....2	<b>5. Twin-Needle Stitching</b> .....26
Principal Parts.....2/3	Threading the Twin-Needle.....26
Accessories.....4	Machine Settings.....27
Optional Accessories.....5	Decorative Twin-Needle Stitching.....27
Changing the Needle.....6	
Changing Presser Feet.....7	<b>6. Free-Motion Stitching</b> .....28
Removing and Replacing Needle Plate.....7	Preparation.....28
Attaching Snap-in Feed Cover.....7	Floral Designs.....29
<b>2. Getting Ready to Sew</b> .....8	
Preliminary Steps.....8	<b>7. Sewing the Professional Way</b> .....30
Connecting and Operating Machine.....8	Sewing Knit and Stretch Fabric.....30
Threading the Machine.....9/10	Stitch Pattern Chart • Guiding and
Winding the Bobbin.....11	Supporting Fabric • Plain Stretch Seams
Inserting a Bobbin.....12	• Overedged Seams • Attaching Elastic
Raising the Bobbin Thread.....12	• Finishes for Hems and Facings
How to Start Sewing.....13	Handling Special Fabrics.....35
Fabric, Thread and Needle Table.....13	Construction Details.....36
Setting Selectors.....14	Zippers • Corded Seams • Blindstitch Hems
Setting Stitch Width.....14	Buttons.....39
Setting a Needle Position.....15	Buttonholes.....40
Regulating Needle-Thread Tension.....16	Four-Step Buttonholing.....41
Setting Stitch Length.....16	Adjusting Forward-Reverse Stitch
Setting Pattern Group Selector.....17	Balance.....43
Setting Stitch Pattern Selector.....17	Buttonholes (Manual Method).....43
<b>3. Straight Stitching</b> .....18	Decorative Touches.....45
Sewing a Seam.....18	Topstitching • Applique
Pin Basting • Starting a Seam • Ending a	Keeping up Appearances.....46
Seam • Guiding and Supporting Fabric	Mending • Darning
<b>4. Zig-Zag Stitching</b> .....21	<b>8. Free-Arm Sewing</b> .....48
How Patterns are Produced.....21	
Selecting and Adjusting	<b>9. Caring for Your Machine</b> .....49
Zig-Zag Stitches.....22	Cleaning and Lubricating.....49
• Selecting a Pattern Group • Selecting a	Removing and Replacing Bobbin Case.....50
Stitch Pattern	To Remove and Replace Face Plate.....51
• Adjusting Width of Design • Adjusting	To Remove Top Cover and Bottom
Stitch Placement	Cover.....51
• Adjusting a Stitch Length • Adjusting	Changing the Light Bulb.....52
Needle-Thread Tension	Replacing the Slide Plate.....52
• Adjusting a Stitch Balance	Hints for Home Service
• Satin Stitching	
	<b>Index</b> .....1

Dear Customer:

We recommend that for the future reference you record the serial number of your Sewing Machine in the space provided.

Refer to illustration for location of serial number, **A**, on your machine.

Serial No. \_\_\_\_\_

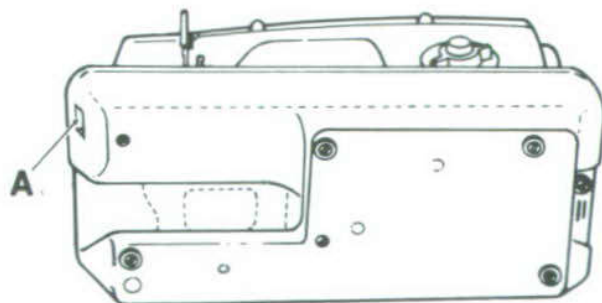

# 1

## Getting to Know Your Machine

### *principal parts-*

- |   |                           |
|---|---------------------------|
| 1. Hand Wheel                                     | 9. Bobbin Winder Tension  |
| 2. Bobbin Winder                                  | 10. Take-up Lever         |
| 3. Spool Holder                                   | 11. Thread Guides         |
| 4. Stitch Pattern Selector<br>(only 8019)         | 12. Built-in Sewing Light |
| 5. Pattern Group Selector<br>(only 8007 and 8019) | 13. Thread Cutter         |
| 6. Stitch Width Selector                          | 14. Presser Foot          |
| 7. Snap-in Thread Guide                           | 15. Zig-Zag Needle Plate  |
| 8. Tension Dial                                   | 16. Slide Plate           |
|   | 17. Needle Clamp          |

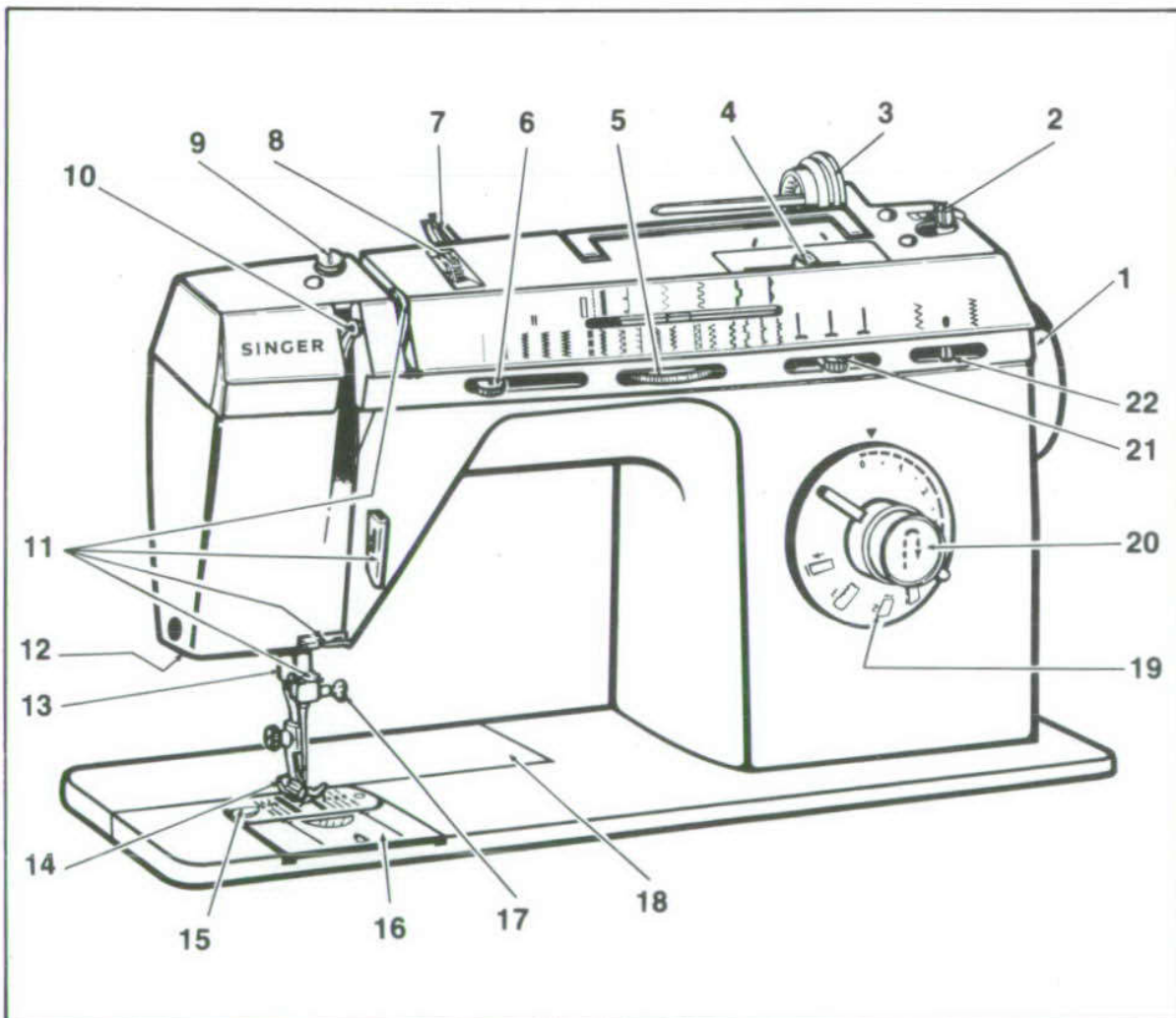

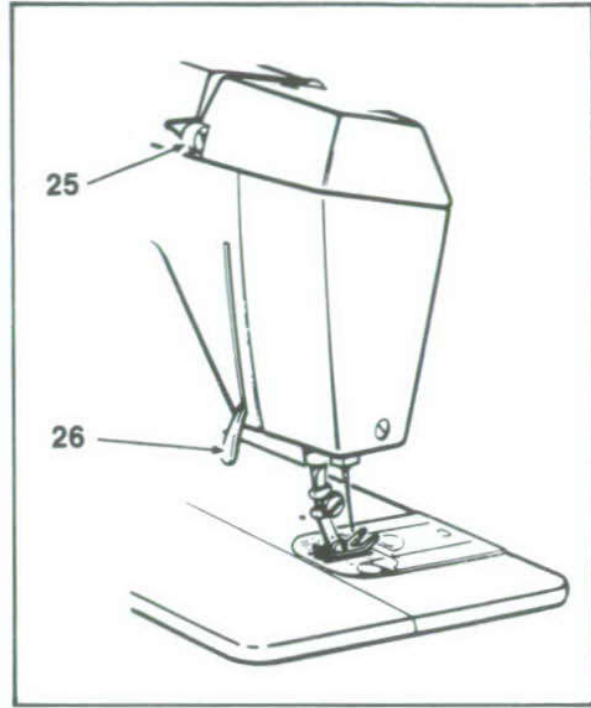
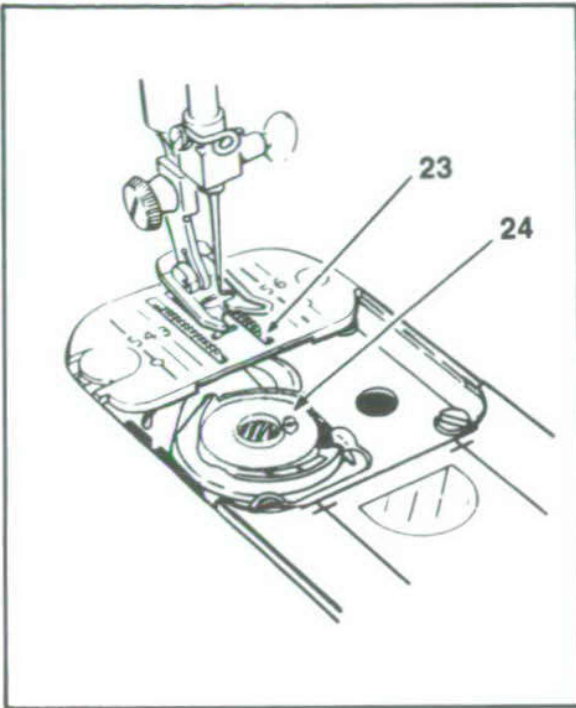

**18. Flip and Sew\* Panel**

- 19. • Stitch Length Selector**  
• Built-in-Four-Step Buttonhole Dial (except 8002)
- 20. • Reverse-Stitch Push Button**  
• Buttonhole Stitch Balancing Control (except 8002)
- 21. Needle Position Selector**
- 22. Stitch Balance Control**  
(except 8002 / 8007)
- 23. Feed System**
- 24. Transparent Bobbin**
- 25. Rear Thread Guide**
- 26. Presser Foot Lifter**
- 27. Bobbin Winding Indent**
- 28. Power and Light Switch**
- 29. Electrical Connections and Speed Controller**

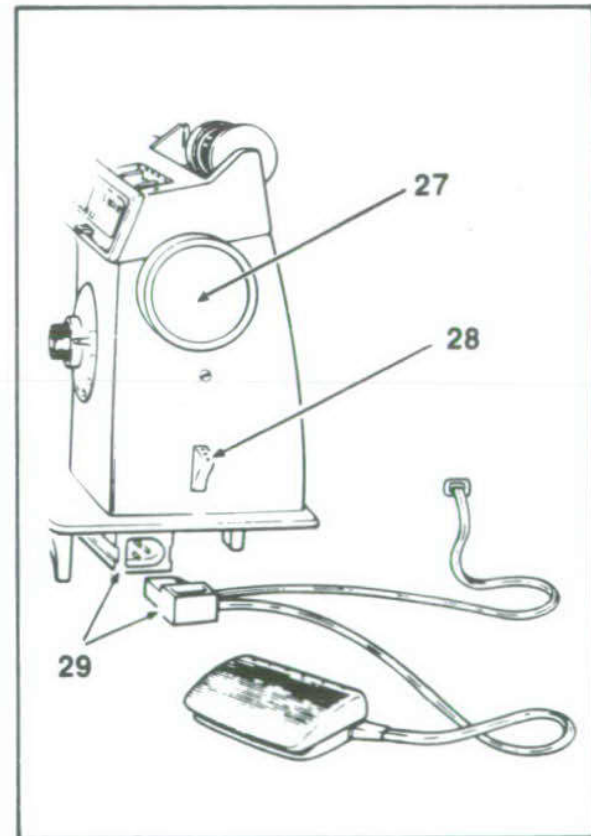

To ensure that you are always provided with the most modern sewing capabilities, the Manufacturer reserves the right to change the appearance, design or accessories of this sewing machine when considered necessary.

\* A Trademark of The Singer Company  
Copyright © 1990 Singer Sewing Machine Company  
All rights reserved throughout the world.

## accessories

The accessories that come with your sewing machine will help you to sew with ease and comfort.

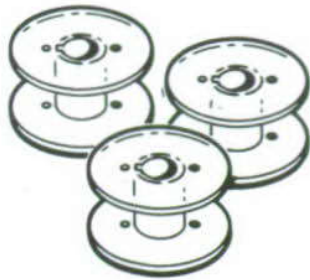

### Transparent Bobbins

- One transparent bobbin in your machine.
- Additional transparent bobbins with your accessories.

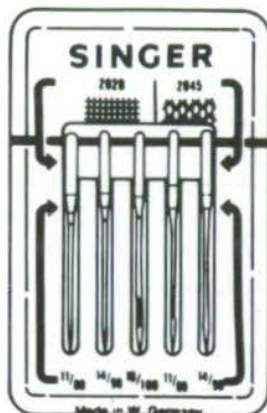

### Needles

**IMPORTANT:** Your sewing machine has been designed to obtain best results with SINGER® needles. You should follow the recommendations in this instruction book and on the needle package for correct style and size of needle for different types and weights of fabric.

- Catalog 2020 needles, for all-purpose sewing.
- Catalog 2045 needles, for sewing synthetic knit and stretch fabrics.

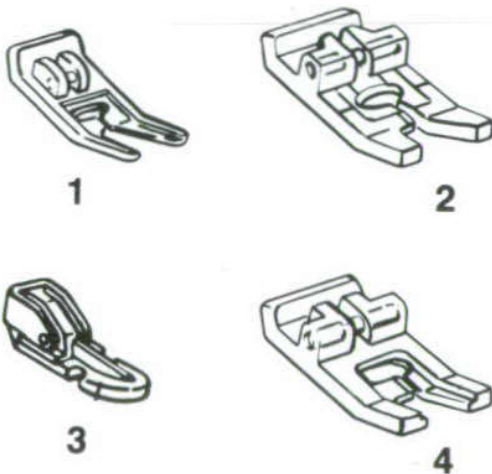

### Presser Feet

Additional interchangeable snap-on presser feet:

1. The zig-zag foot on your machine.
2. Buttonhole foot to make square-end buttonholes. (only 8007 and 8019)
3. Zipper foot for inserting zippers and stitching corded seams.
4. Special purpose foot for all kinds of decorative zig-zag stitching.

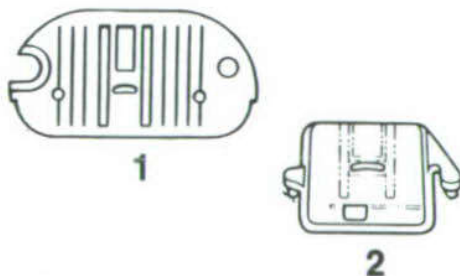

### Needle Plates

1. The **zig-zag needle plate** on your machine can be used with all presser feet.
2. The **snap-in feed cover** is used for button sewing, free-motion work and darning.



### Thread Lead-Off

This lead-off holds narrow-diameter spools of thread on the spool pin. (See page 9)



### Container Of Oil

One container of oil.  
Your machine will serve you perfectly for many years if you will take a few moments to keep it in good operating condition.

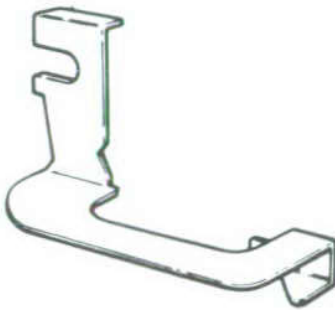

### Blindstitch Hem Guide

The blindstitch hem guide, used with the zig-zag foot, positions the hem fold in front of the needle for blindstitch hemming. To attach guide, loosen presser foot shank. Make sure underside of guide clears the slide plate and front of foot.

Tighten presser-foot screw.

(only 8007 and 8019)

## Optional Accessories



- Catalog 2025† needle for twin-needle work.

†**CAUTION:** Use this needle with the zig-zag plate and zig-zag foot or special-purpose foot only. Do not use any other accessories with this needle as needle breakage will occur.



- Straight stitch foot for close fabric control.



- One-piece presser foot for button sewing.



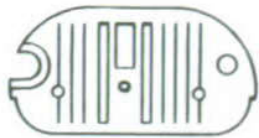

The **straight stitch needle plate** is for use with the straight stitch presser foot.



### Spool Pin For Twin-Needle Stitching

This spool pin permits you to stitch two parallel rows of stitching simultaneously (see page 26 for detailed instructions).



### Lint Brush

The lint brush is used for cleaning your sewing machine.

## Changing The Needle

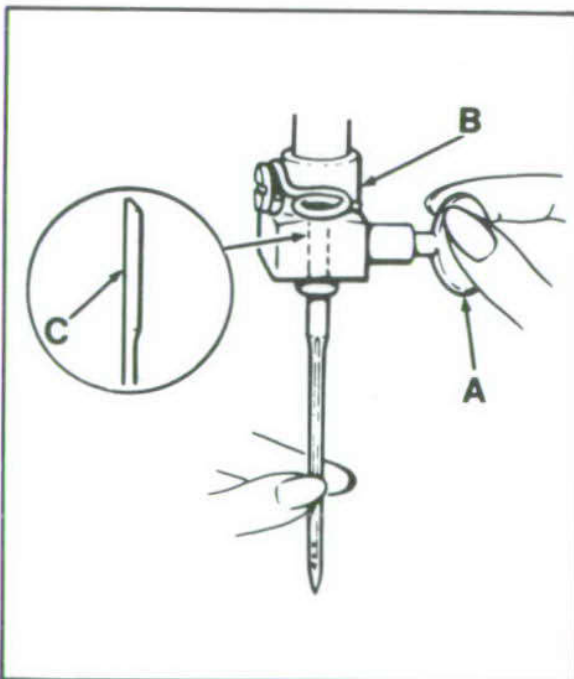

1. Raise the needle to its highest position by turning the hand wheel *toward you*.
2. Loosen the needle-clamp screw **A** and remove needle.
3. Insert new needle in clamp **B** with the *flat side C* of the needle to the back; push it up as far as it will go.
4. Tighten the needle-clamp screw.

## Changing Presser Feet

Most presser feet furnished with your machine snap on and off a common shank.

- Raise needle and take-up lever to highest position by turning hand wheel toward you.
- Raise presser foot.

To remove the complete presser foot (with shank), or snap-on presser feet and one-piece presser foot for button sewing, loosen the presser foot screw and remove shank and foot together.

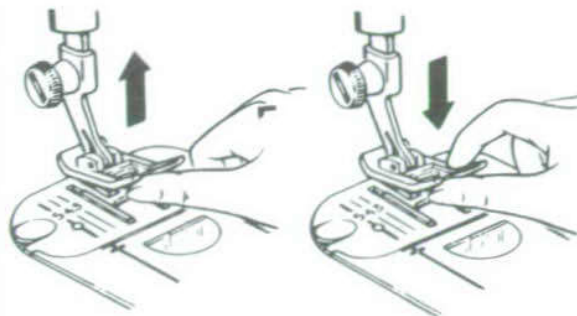

1. Press toe of presser foot upward as far as it will go. Then snap down to remove.

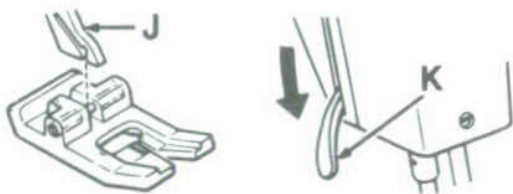

2. Center the new presser foot under the shank J.

Lower the presser foot lifter K so that the shank fits over the presser foot pin.

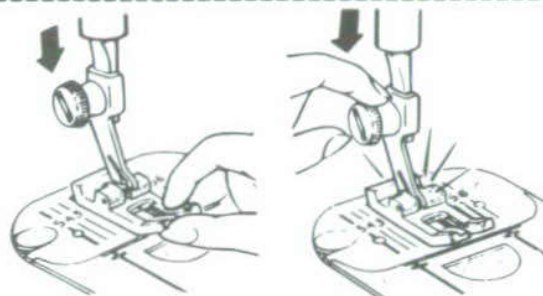

3. Press presser foot screw down firmly until foot snaps into place.

## Removing and Replacing Needle Plate

- Raise presser foot.
- Turn hand wheel toward you until the needle is in its highest position.
- Open the slide plate. Lift needle plate up and to the right until it snaps free.
- Insert new needle plate by placing it under the clamping pin (1) push it gently to the left and press down until it snaps into place.
- Close slide plate.

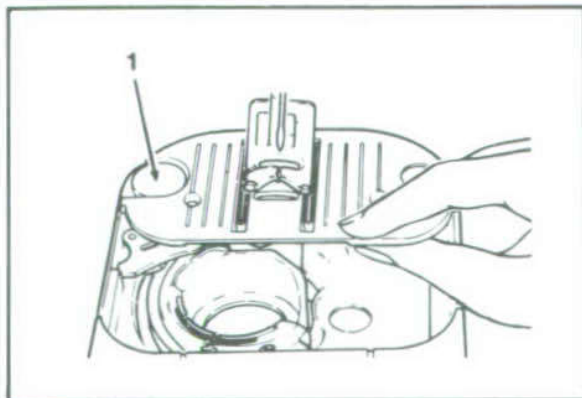

## Attaching Snap-In Feed Cover

- Raise needle to highest position by turning hand wheel toward you.
- Raise presser foot, open slide plate and insert zig-zag needle plate.
- Slide snap-in feed cover away from you over needle plate until points (1) and (2) are positioned directly over holes in needle plate as illustrated. Snap in point (1). Then push (2) in toward point (1) until it snaps into place. Close slide plate.
- To remove, open slide plate then simply lift up front edge of feed cover, and remove. Close slide plate.

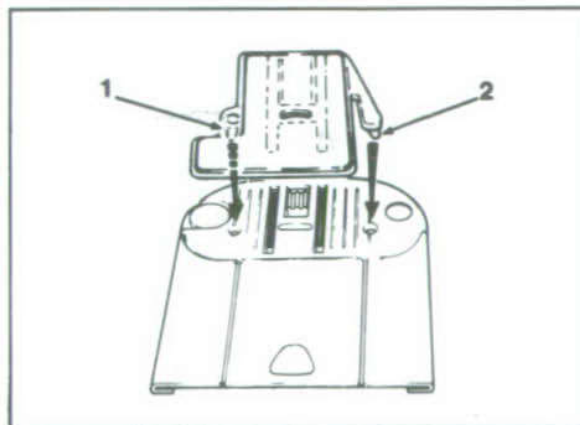

# 2

## Getting Ready to Sew

### *preliminary steps*

#### **Connecting Machine**

Before plugging in your machine, be sure that the voltage and frequency indicated on the right end of the machine are within the range marked on the electric meter installed by your power company.

Insert the machine plug **A** into the machine socket **B** at the right end of the machine, and connect the power-line plug **C** to your electrical outlet.

**CAUTION:** Disconnect the power-line plug from the socket outlet when changing needle, feet or needle plates or when leaving the machine unattended. This eliminates the possibility of starting the machine by accidentally pressing the speed controller.

**To run the machine,** press the speed controller **E** with your foot. The harder you press, the faster the machine will sew. To stop machine, remove foot from controller.

#### **Operating Machine**

To turn on the machine and sewing light, press upper portion of power switch (D).

**CAUTION:** Because of the up and down movement of the needle, you must work carefully and watch the sewing area when operating the machine.

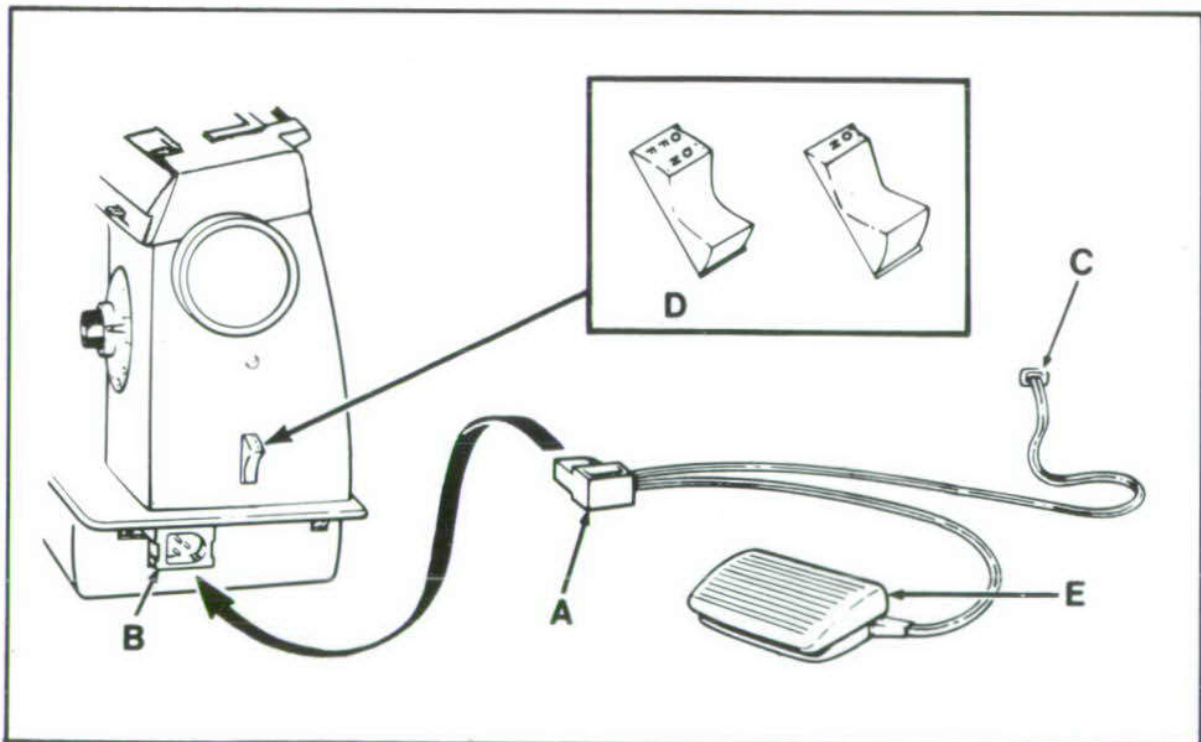

# Threading The Machine

1. Raise presser foot and be sure needle is in its highest position.

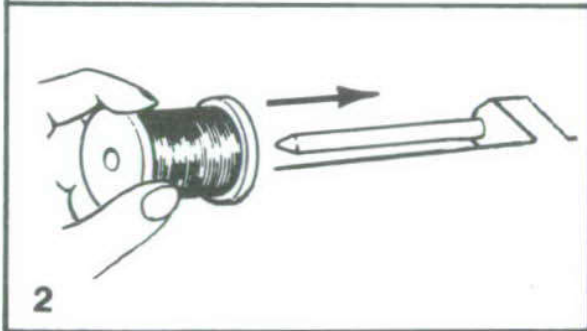
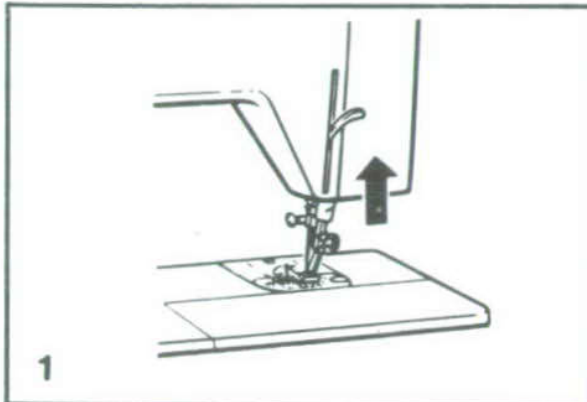

2. Place spool of thread on horizontal spool pin. If spool being used has a retaining slit, this should be placed to the right.

3. Press appropriate thread lead-off holder firmly against spool.

A. For large spools of thread, use the large holder with the wide end against the spool.

B. For medium size spools, use the large holder with the narrow end against the spool.

C. For small diameter spools with either large or small quantities of thread, use the small lead-off which comes in your accessory box.

4. Lead thread from spool holder and snap it down into guidepost eyelet **a**.

5. Hold thread down under finger, as illustrated, and lead thread-under rear thread guide **b**, behind pre-tension disc, and across slot in top of machine.

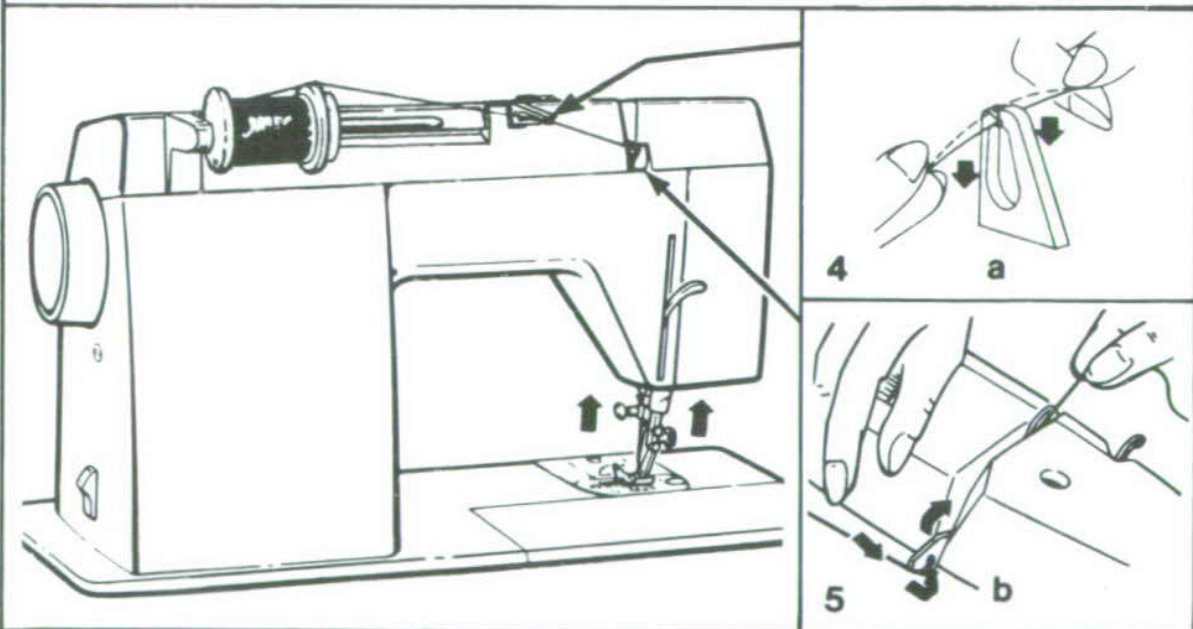
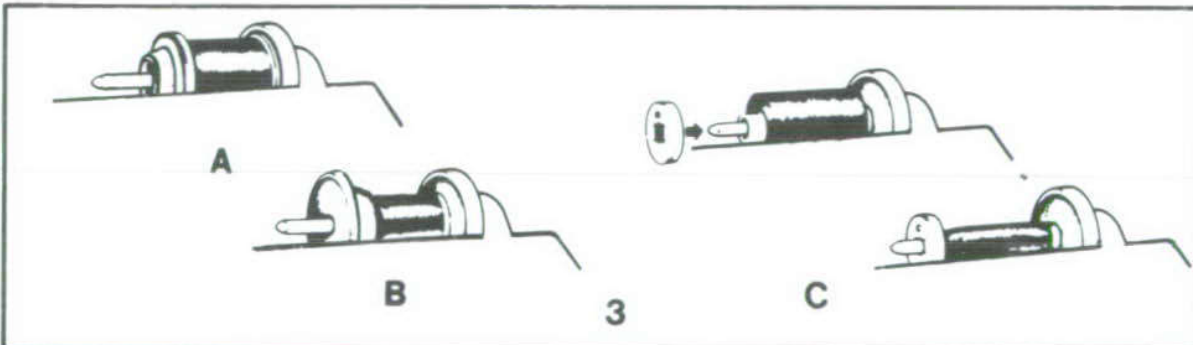

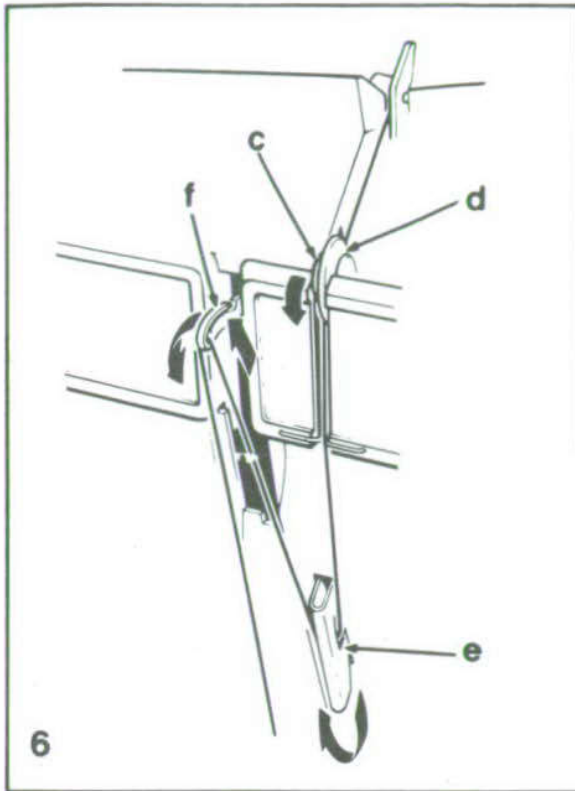

6. Draw thread firmly between left tension disc **c** and tension separator **d**, then down around thread guide **e** on front of machine. (Presser foot must be raised to allow thread to enter discs.)

7. Thread take-up lever **f** by guiding thread through slot **g** and into eyelet **h**.

8. Lead thread from take-up lever down to lower thread guides **i**, as shown, and thread needle from front to back. Draw 10cm (4") of thread through needle eye **j**.

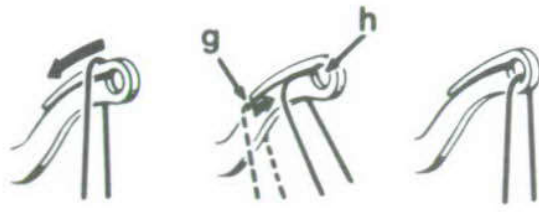

6

7

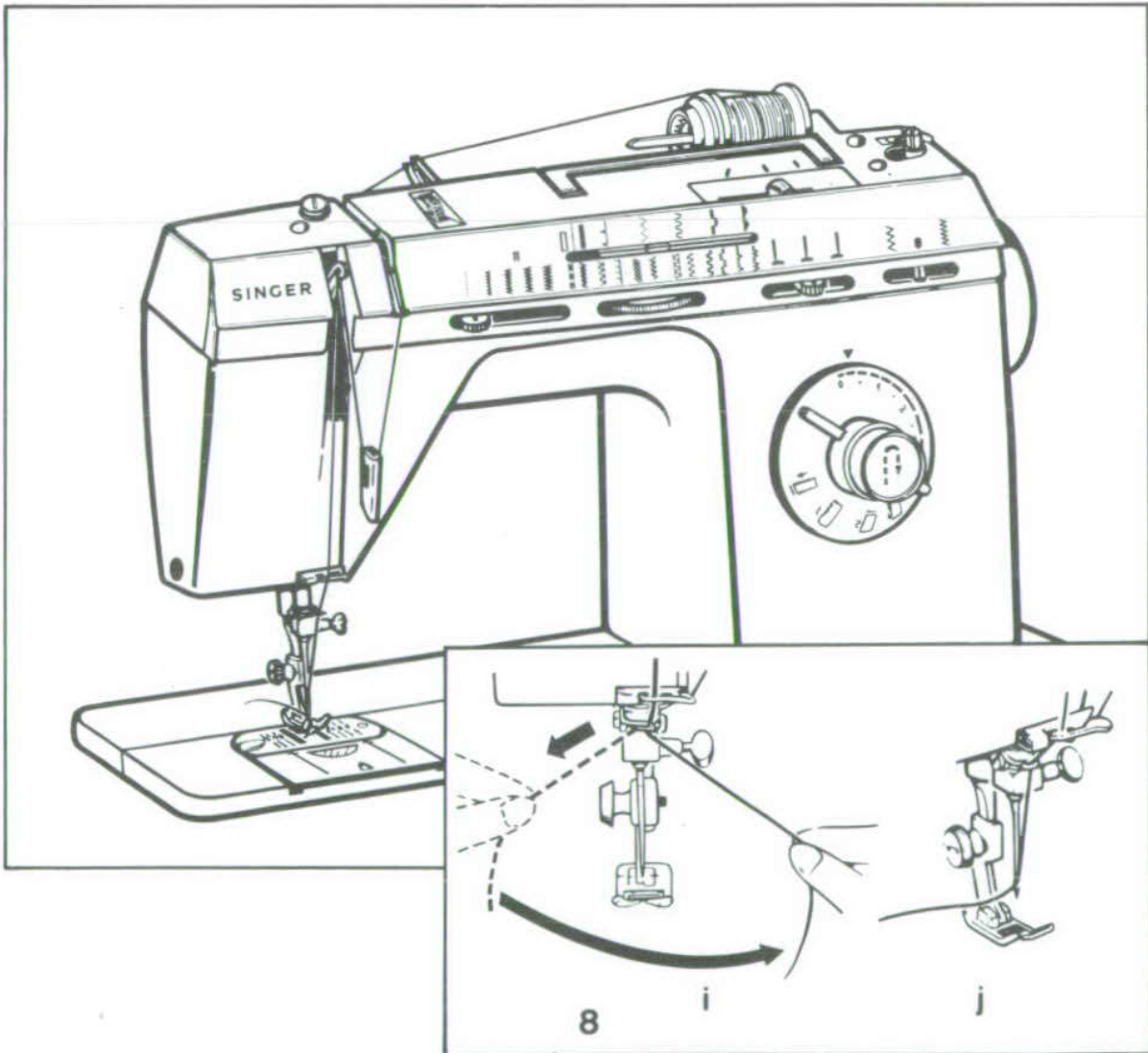

8

## Winding a bobbin

Winding a bobbin is quick and easy when you follow the directions below. Always wind the bobbin before threading the machine and needle.

- Push in indent (1) on hand wheel disc. This will stop the needle from moving.
- Place spool of thread on spool pin.
- Slide spool cap (2) firmly over rim of spool to prevent thread tangling.
- Lead thread from spool and snap into thread guide post (3).
- Wind thread clockwise around front of bobbin winder tension disc (4).
- Pass thread end, from inside, through small hole in rim of bobbin.
- Place bobbin on spindle and push it to the right.
- Holding thread end, step on speed controller to run machine until desired amount of thread is wound. (Winding stops automatically once bobbin is full.)
- Cut thread; push bobbin to the left and remove it from spindle.
- Trim thread end from top of bobbin.
- Return hand wheel disc to sewing position by pressing on side opposite indent.

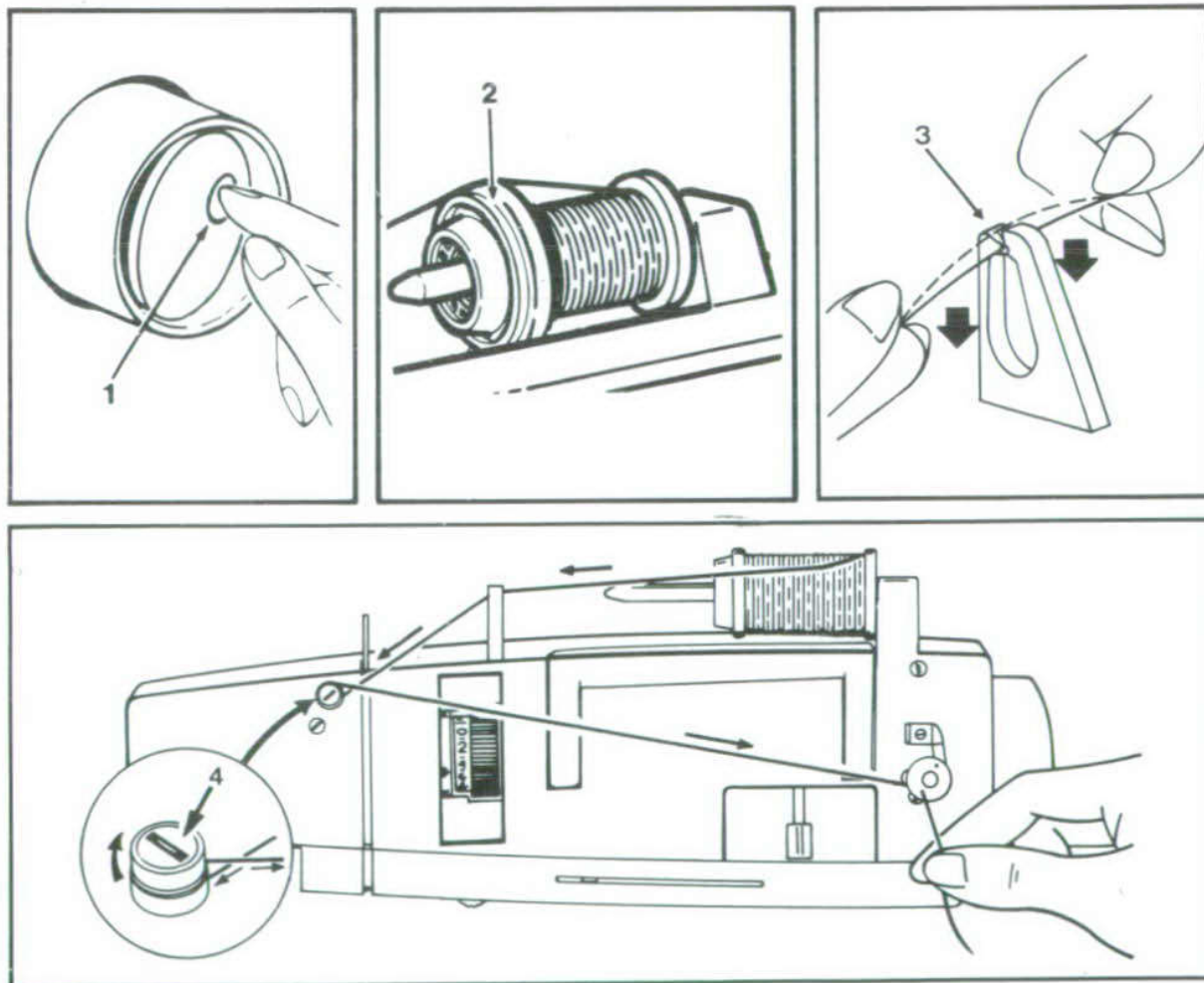

## Inserting a bobbin

To insert a bobbin, follow the instructions below:

- Raise presser foot.
  - Turn hand wheel toward you until needle is in its highest position.
  - Open slide plate and remove empty bobbin.
1. Pull 4" (10cm) of thread from replacement bobbin and insert bobbin into case, as shown.
  2. Holding bobbin in place, guide thread into notch (1) and then down the slot to the left and guide around into notch (2).
- Draw several inches of thread diagonally across the bobbin toward the back of the machine.
  - While holding thread on outside, close the slide plate, allowing thread to extend through the slot between the slide plate and needle plate.
  - Follow directions for "Raising Bobbin Thread" below.

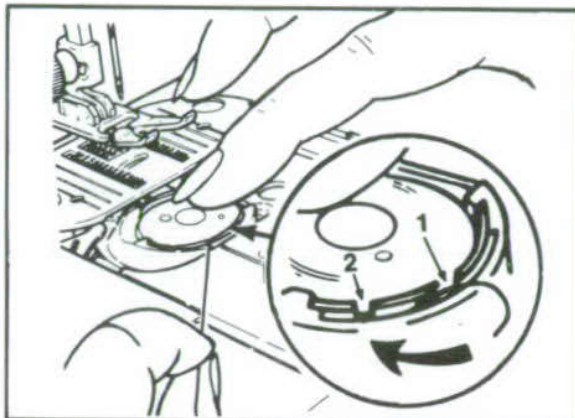
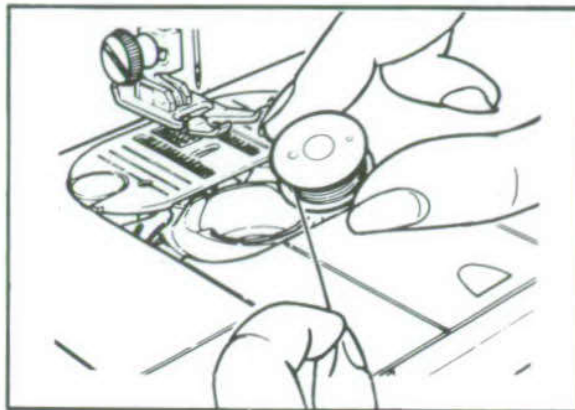

## Raising the Bobbin Thread

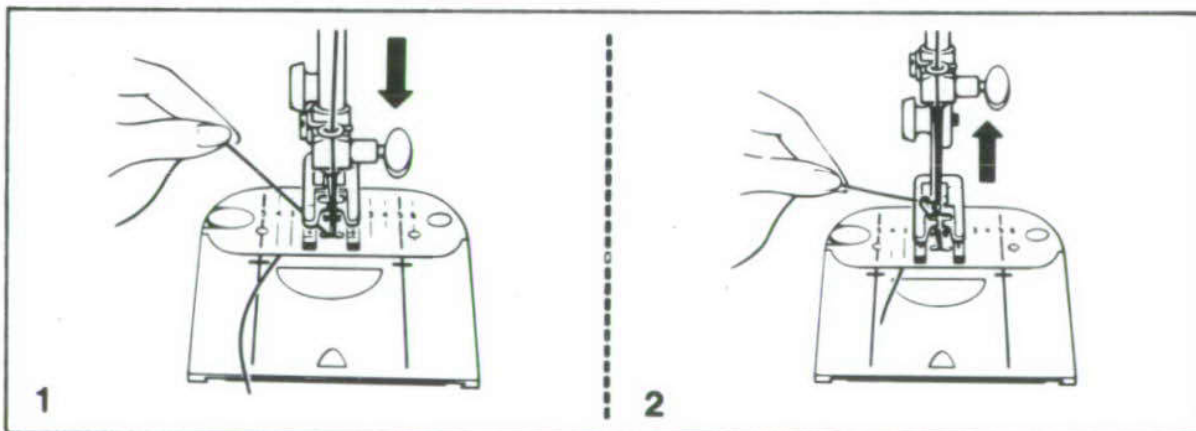

1. Hold needle thread lightly with left hand and turn hand wheel slowly toward you so that needle enters needle plate.
2. Continue turning hand wheel until needle rises and brings up bobbin thread in a loop.
3. Undo the loop and place both threads under the presser foot, drawing them to the back of the machine. Position needle in fabric where desired, lower the presser foot and stitch.

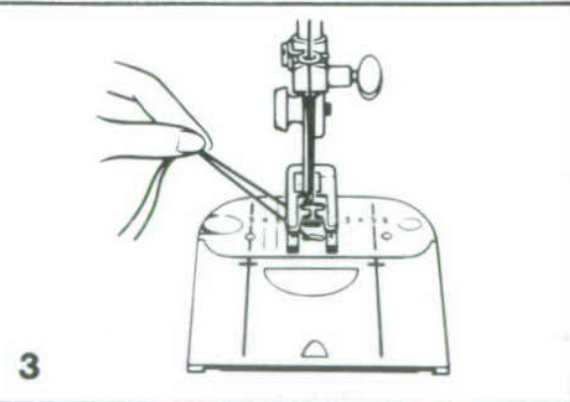

## how to start sewing

How you begin to sew after winding a bobbin depends on whether your stitching is to start at or away from the edge of the fabric.

### To Start At Fabric Edge

- Pull thread back under presser foot.
- Position needle in very edge of fabric by pressing speed controller lightly or turning the hand wheel.
- Lower the presser foot and stitch.

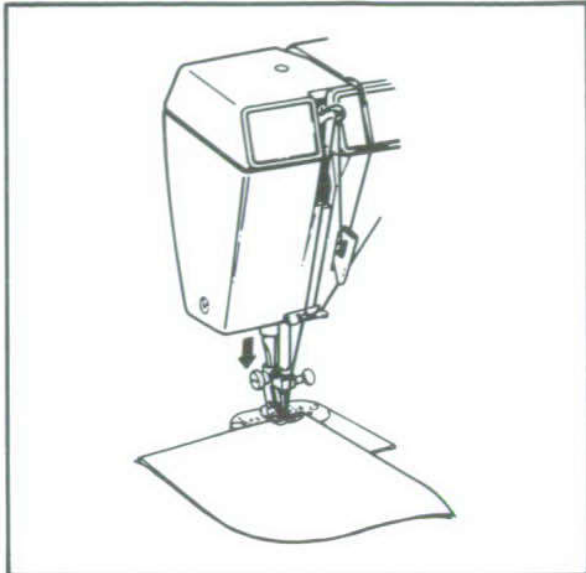

### To Start Away From Fabric Edge

- Pull thread back under presser foot.
- Position needle in fabric where desired.
- Lower the presser foot and stitch.

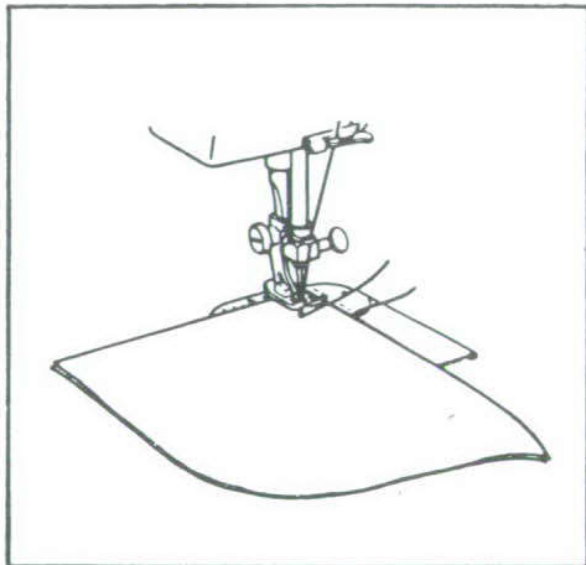

## Fabric, thread and needle table

The needle and thread you choose will depend upon the fabric being sewn.

The table is a practical guide to needle and thread selection.

Always refer to it before beginning a sewing project. Be sure to use the same size and type of thread in both needle and bobbin.

The fabrics below can be of any fiber: cotton, linen, silk, wool, synthetic, rayon, blends. They are listed as examples of weight. **NEEDLES**

	Fabrics	Thread	Type	Size
<b>Light-Weight</b>	Batiste Chiffon Crepe	Cotton-wrapped Polyester 100% Polyester †Mercerized Size 50 Nylon	2020	11/80
<b>Medium-Weight</b>	Corduroy Flannel Gabardine Gingham Linen Muslin Wool Crepe	Cotton-wrapped Polyester 100% Polyester †Mercerized Size 50 Nylon	2020	14/90
<b>Medium-Heavy</b>	Bonded Wovens Canvas Coating Denim Duck Sailcloth	Cotton-wrapped Polyester 100% Polyester †Mercerized Size 40 †"Heavy Duty"	2020	16/100 18/110
<b>Knits</b>	Bonded Knits Double Knit Jersey Tricot	Cotton-wrapped Polyester Polyester Nylon		Ball-Point 2045 Size 11/80, 14/90,

†Not recommended on stretch fabrics



## setting selectors

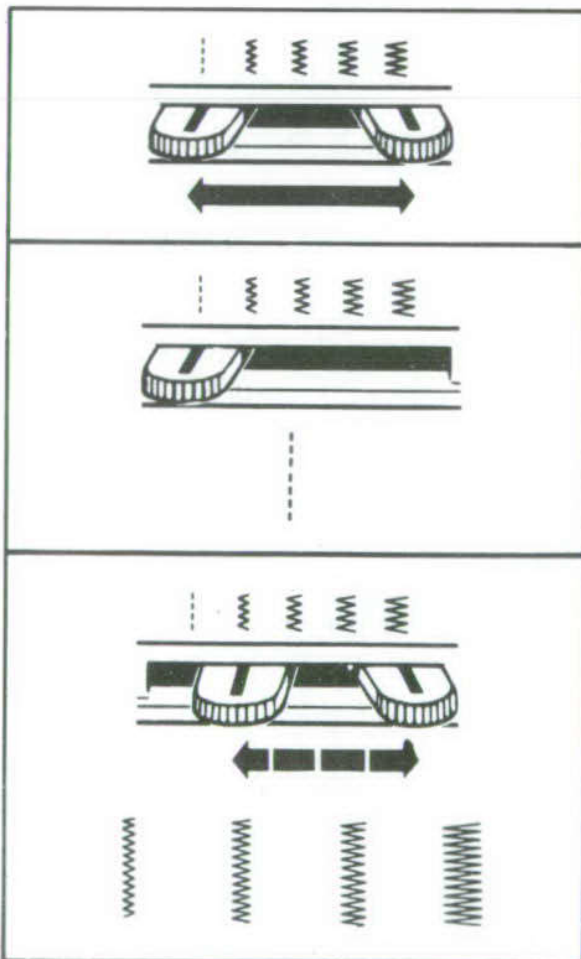
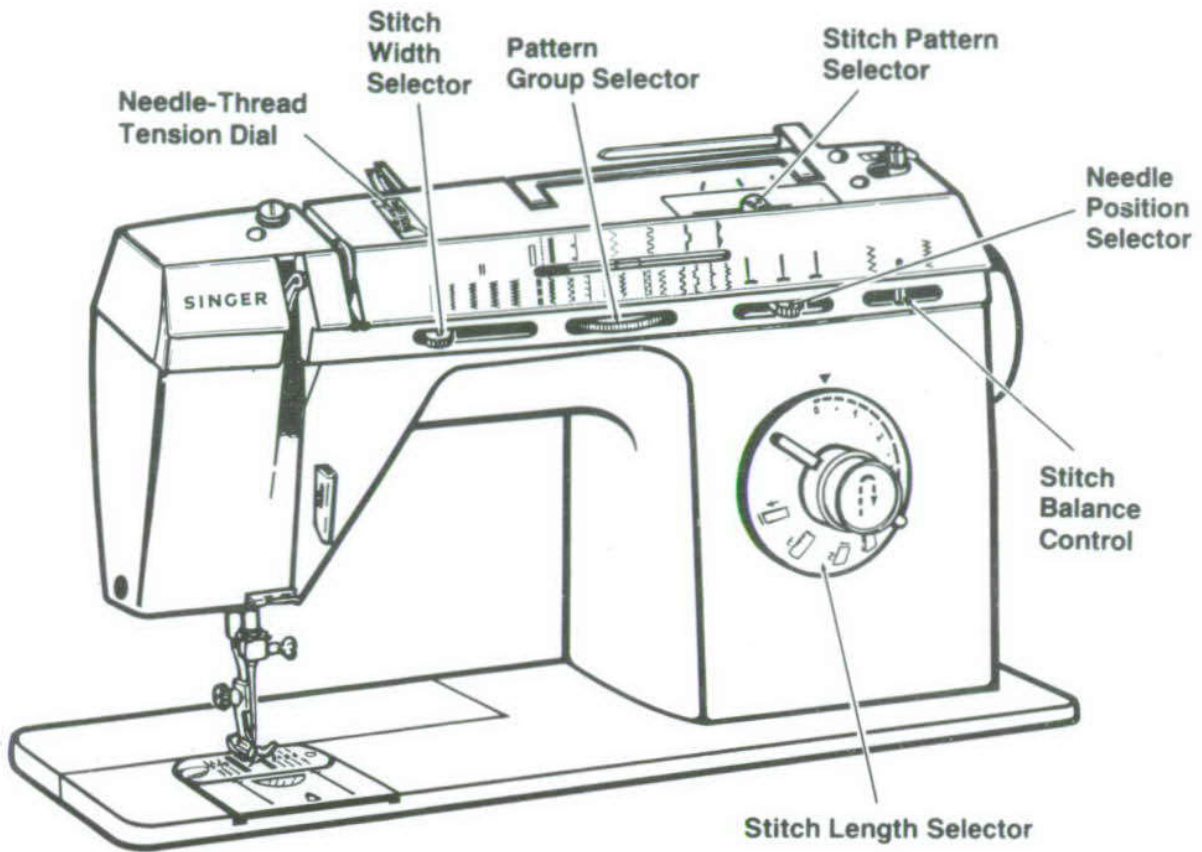



### Setting Stitch Width

The stitch width selector does two jobs; it sets the machine for straight stitching, and it controls the width of zig-zag stitching. Four stitch width settings are indicated plus a setting for straight stitching.



*Before moving the selector, make sure needle is above the fabric.*

**To set stitch width,** slide the selector lever until indicator line is aligned with desired setting.

**Straight Stitching:** Set the selector at :

**Zig-Zag Stitching:** To suit sewing application, set the selector at any zig-zag position between  (narrow-position) and  (wide-position).







## Setting a Needle Position

The needle position selector **B** places the needle in left (  ), center (  ) or right (  ) stitching position. You will need to set it before you start running the machine.

*Before moving the selector, always make sure the needle is out of the fabric.*

To position the needle, slide the lever to left or right until indicator line is under desired setting.

**Straight-Stitching:** Normally you will use the center (  ) needle position. But if you wish to place the stitching at left or right of center, slide the lever to desired position. The zig-zag needle plate and zig-zag foot must be used if left or right needle positions are selected.

**Zig-Zag Stitching:** You will use center (  ) position most often. Left (  ) and right (  ) positions are for special stitch placement. For example: A  setting is used for button sewing. Settings  and  are used to place narrow zig-zag stitching to the left and right of center in decorative work.

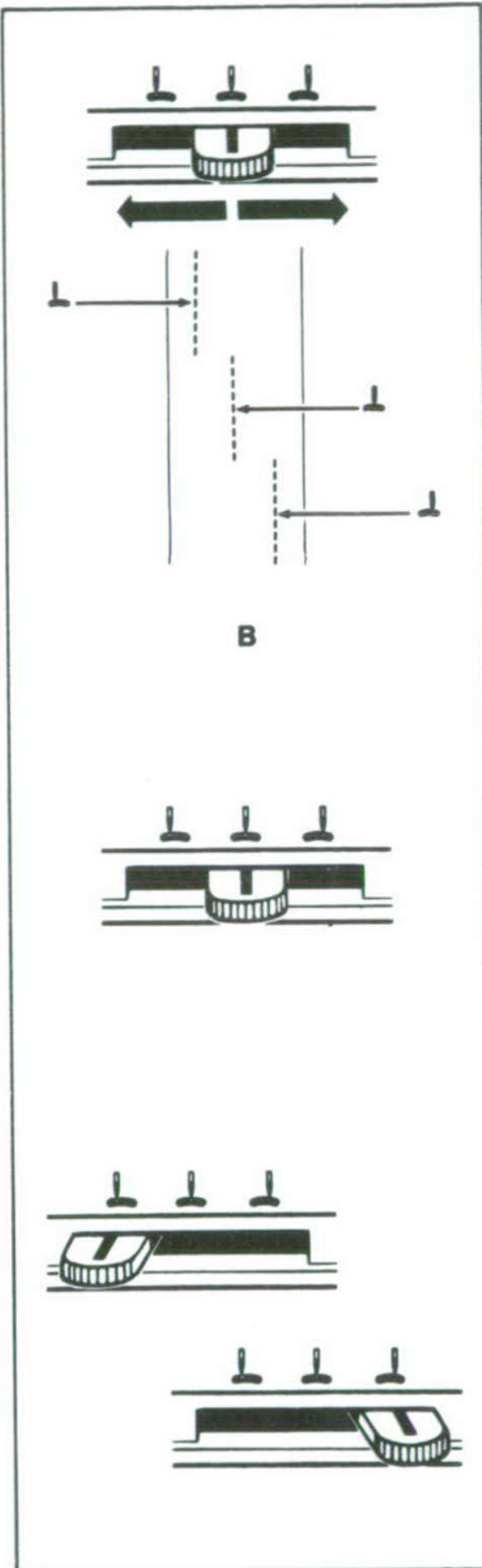

## Regulating Needle-Thread Tension

The needle-thread tension dial regulates the amount of tension on the needle thread and lets you select just the right setting for your fabric and thread. The numbers on the dial eliminate guesswork in duplicating settings.

Correct **A** tension is important because too much or too little will weaken your seams or mar the appearance of decorative work. To determine the correct tension, make a test on a sample of your fabric. If the stitches look loose **B**, increase tension. If the fabric puckers **C**, decrease tension.

(For instructions on adjusting zig-zag stitch tension, see page 24.)

- To increase tension, turn to higher number.
- To decrease tension, turn to lower number.

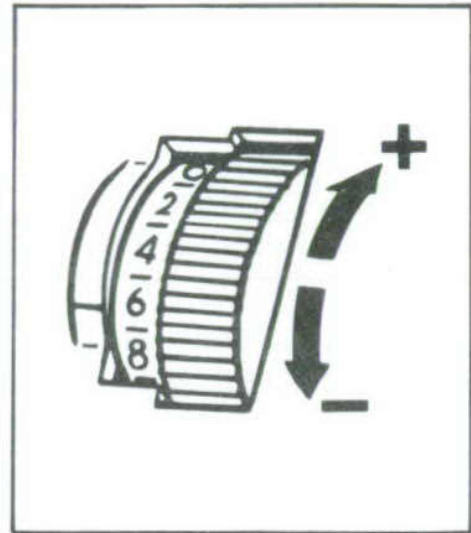
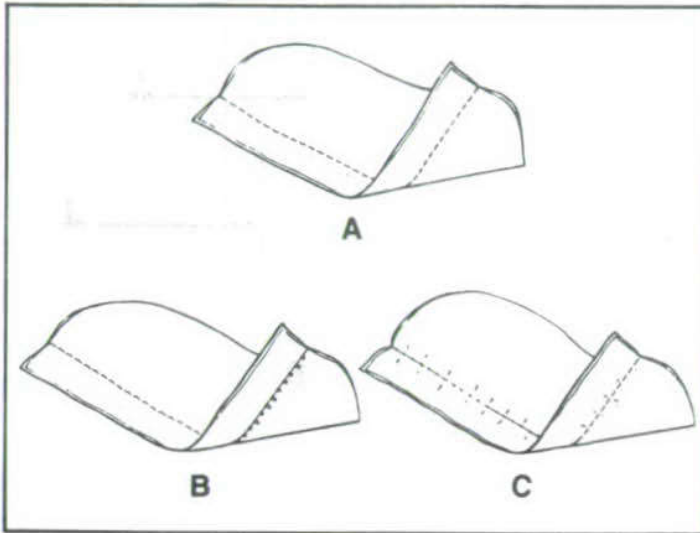

## Setting Stitch Length

The stitch length selector dial controls the length of both straight and zig-zag stitching. The numerals from 1 to 4 represent the length of each stitch in millimeters: the higher the number, the longer the stitch. Generally, shorter stitches are best for lightweight fabric, longer ones for heavier fabric.

The area between 0 and 1 represents stitches less than 1mm long, and is used for closed zig-zag or satin stitching.

- To shorten stitch length, turn dial clockwise **A** to a lower number.
- To lengthen stitch length, turn dial counterclockwise **B** to a higher number.

**For reverse stitching**, depress push button **C** located in center of dial, hold in until reverse stitching is completed, then release push button. Push button can be depressed while machine is sewing.

**Note:** Reverse stitching cannot be done when using a *Flexi-Stitch*® pattern

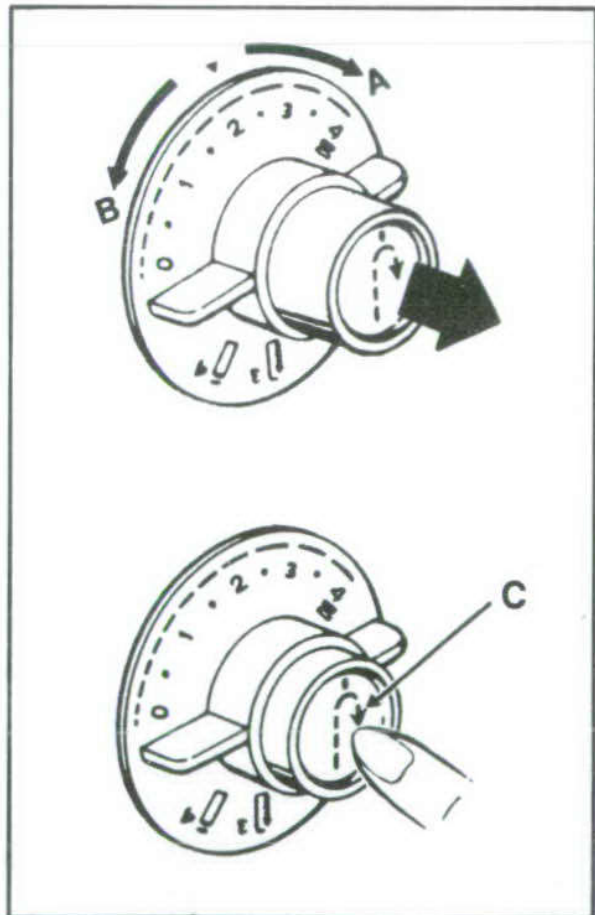

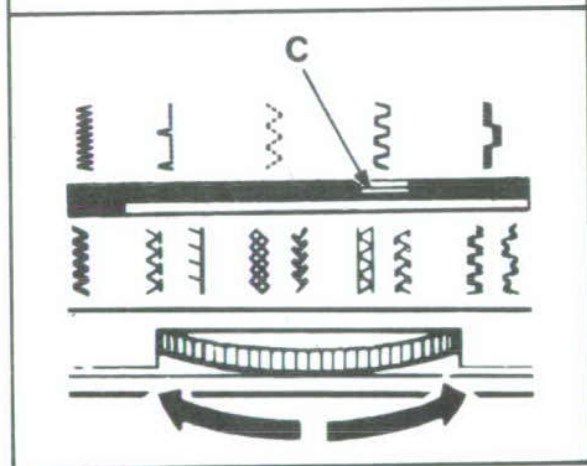
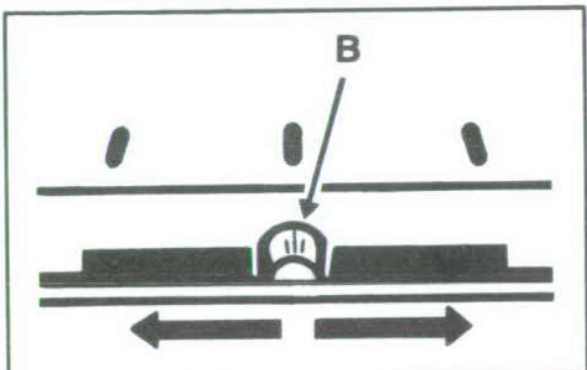
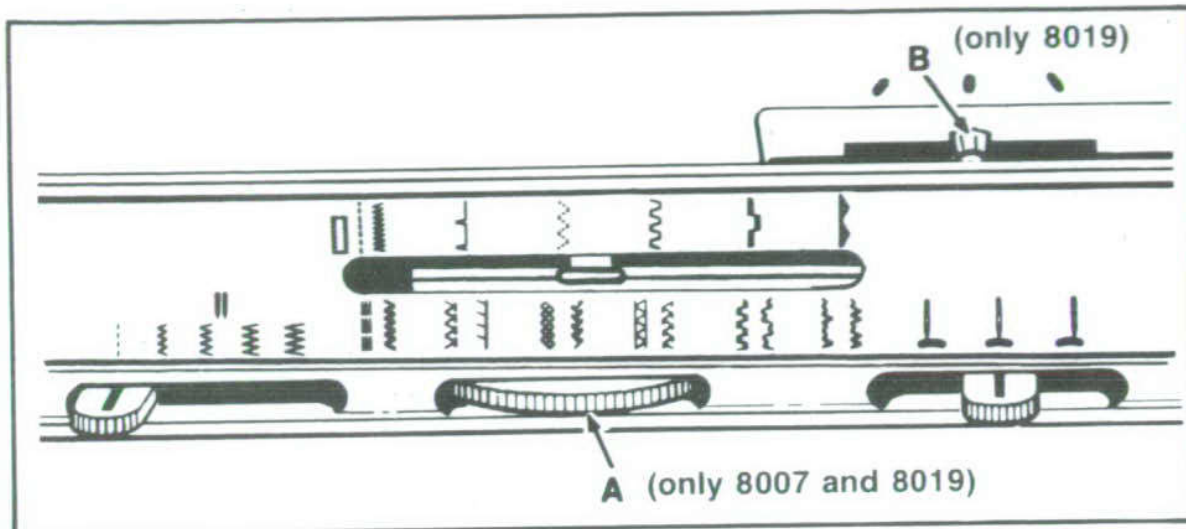

### Setting Pattern Group Selector (A)

The pattern group selector **A** gives you a choice of six groups each containing three patterns. Raise the needle to its highest position.

- Set the stitch width selector to the straight position ( : ). (This allows the pattern selector to be moved easily).
- Rotate the pattern group selector to the centre of the desired pattern group.

Select a pattern group before you set the stitch pattern selector **B**.

**To select a pattern group**, rotate selector until the indicator **C** show the group you have selected. Then set stitch pattern selector for the selected pattern colour following the directions below.

### Setting Stitch Pattern Selector (B)



The stitch pattern selector lets you choose one of the three stitches from the pattern group you have chosen.

# 3

## Straight Stitching

### setting selectors

Before making any setting adjustments, raise the needle out of the fabric.

- Pattern Group: Any Yellow Pattern
- Stitch Width: 
- Needle Position: 
- Stitch Length: To suit fabric
- Zig-Zag or Straight Stitch Foot

When your fabric or sewing procedure requires close control, you may wish to use the straight stitch presser foot and the straight stitch needle plate that come with your accessories.

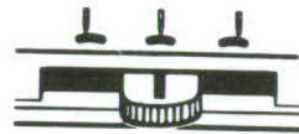
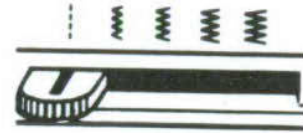

(optional)

### sewing a seam

#### Pin Basting

Pin basting is a time saver and can be used in place of hand basting when you are sewing seams in easy-to-handle fabrics. When sewing with pins it is important to use fine pins and to place them correctly in relation to the stitching line.

Place pins so that:

- They are at right angles to the stitching line.
- They just nip into the fabric at the stitching line.
- They do not extend under both sides of the presser foot. *Never place pins on the underside of the fabric in contact with the feed.*
- Sew, pulling pins out of fabric as you stitch. *We do not recommend sewing over pins.*

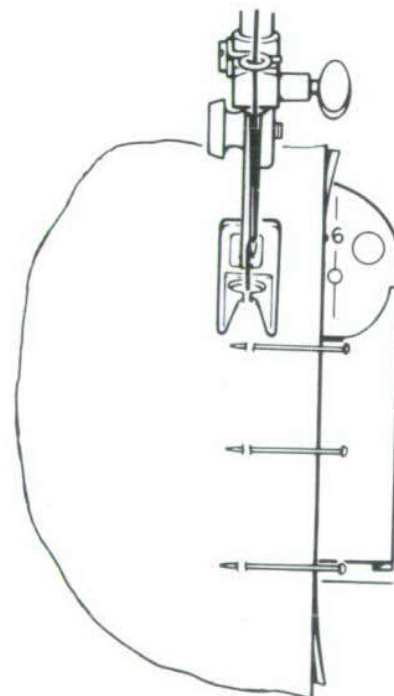

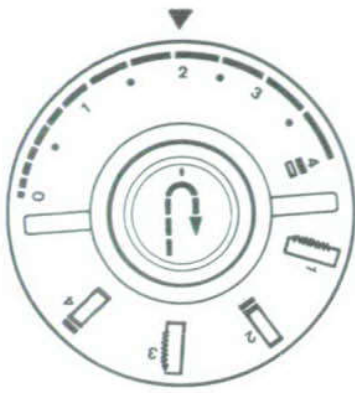

1

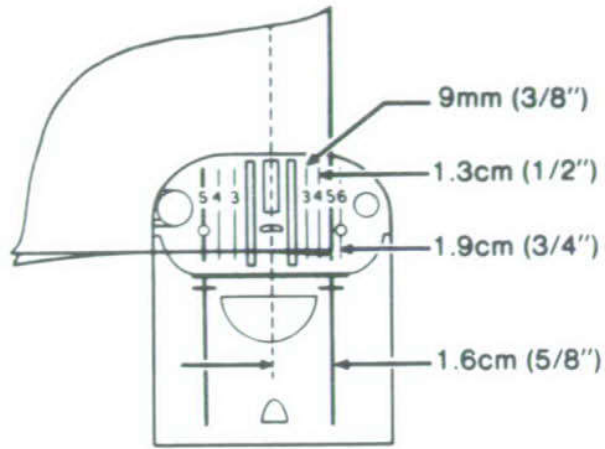

2

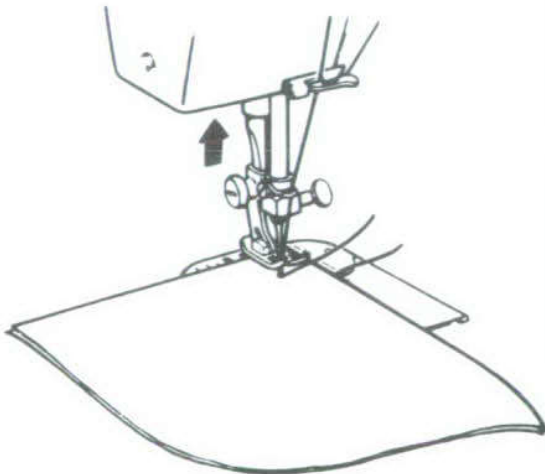

3

### Starting a Seam

1. Set stitch length selector for desired length of stitch.
2. Align edge of fabric along one of the numbered guidelines on the needle plate.
3. Position needle in fabric about 1.3cm (1/2") from the edge.
4. Lower the presser foot. Depress and hold reverse-stitch push button, and run the machine at a slow speed.
  - While holding reverse-stitch push button, back-stitch to edge of fabric for reinforcement. (Do not sew beyond edge of fabric).
5. Release push button and stitch forward to end of fabric, using the selected guideline to keep seam straight.

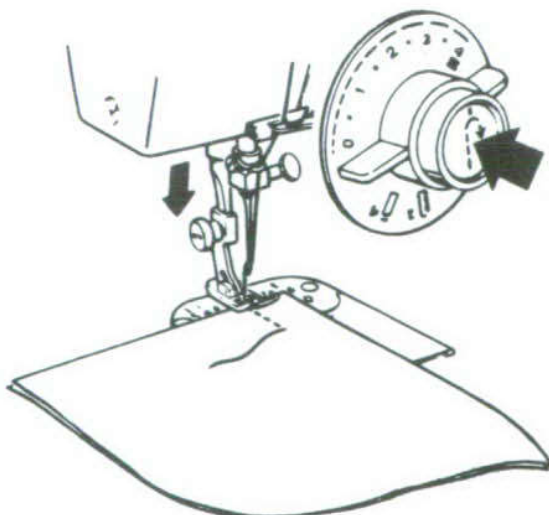

4

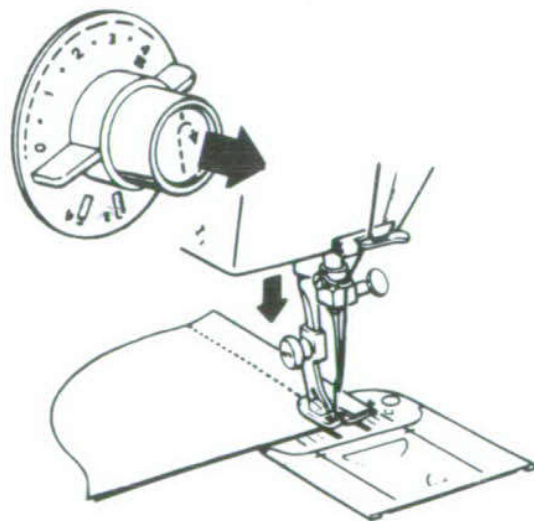

5

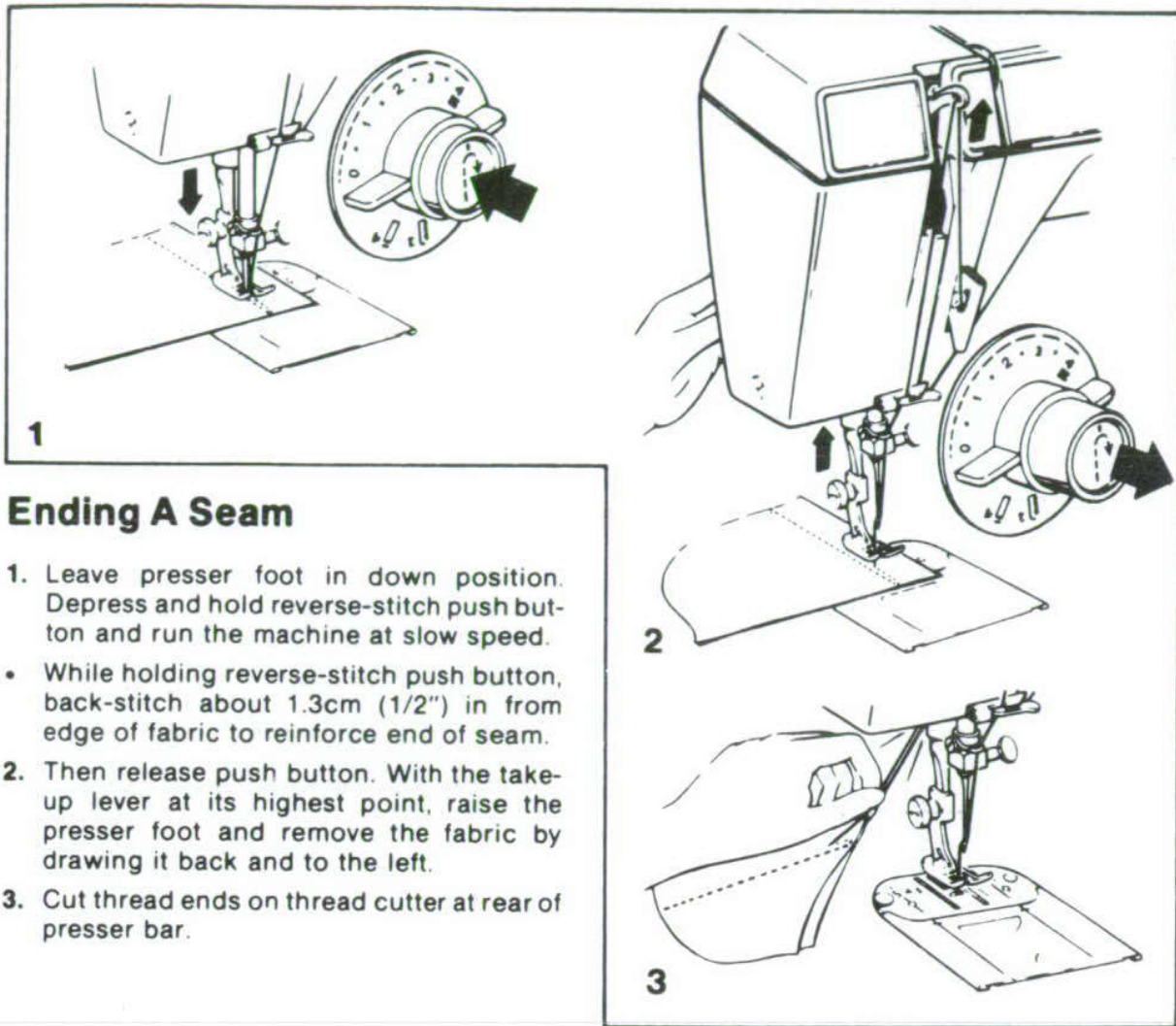

## Ending A Seam

1. Leave presser foot in down position. Depress and hold reverse-stitch push button and run the machine at slow speed.
  - While holding reverse-stitch push button, back-stitch about 1.3cm (1/2") in from edge of fabric to reinforce end of seam.
2. Then release push button. With the take-up lever at its highest point, raise the presser foot and remove the fabric by drawing it back and to the left.
3. Cut thread ends on thread cutter at rear of presser bar.

## Guiding and Supporting Fabric

4. Most fabrics need only to be guided in front of the presser foot.

**CAUTION:** Do not pull the fabric as you apply gentle or firm tension while stitching, as this may deflect the needle, causing it to break.

5. Some fabrics, such as filmy sheers, knits, etc., require support in front and back of the presser foot while being stitched.

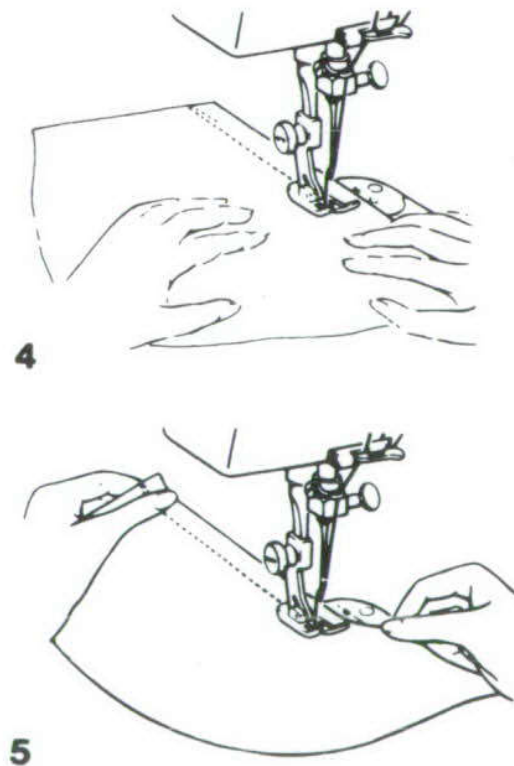

# 4

## Zig-Zag Stitching

### how patterns are produced

There are two kinds of stitch patterns built into your machine: Fashion \* Stitch patterns **A** (only 8007 and 8019) and Flexi-Stitch\* patterns **B** (only 8019).

The Fashion Stitch patterns, colour-coded yellow on your machine are produced by the side to side movement of the needle. The Flexi-Stitch patterns, colour coded green and blue or pink (identified by † in the illustration below ) are produced by both the side to side movement of the needle and the back and forth movement of the feed to produce multipurpose and decorative stitch patterns.

The six groups of three stitches each that are built into your machine are illustrated below.

†SLOW speed setting is recommended for sewing Flexi-Stitch patterns.

This stitch is designed for strength and performance and cannot readily be ripped out without risk of fabric damage.

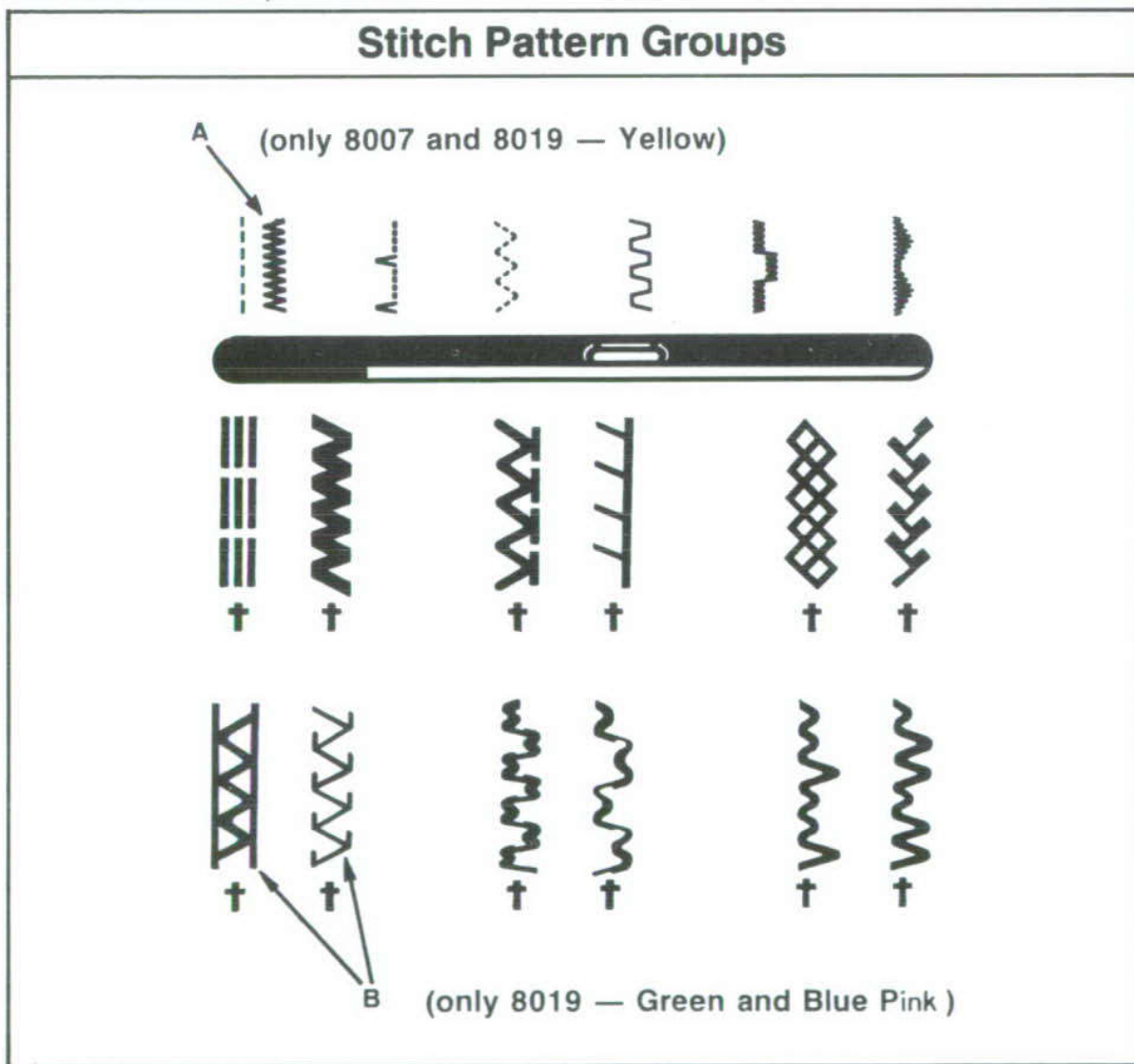



## selecting and adjusting zig-zag stitches

### Selecting a Pattern Group

(only 8007 and 8019)

When you rotate the pattern group selector **C** one of six different groups of pattern stitches is available to you. Rotate the pattern group

selector as required, sliding the indicator through the panel, until it positions one of the pattern groups you've chosen.

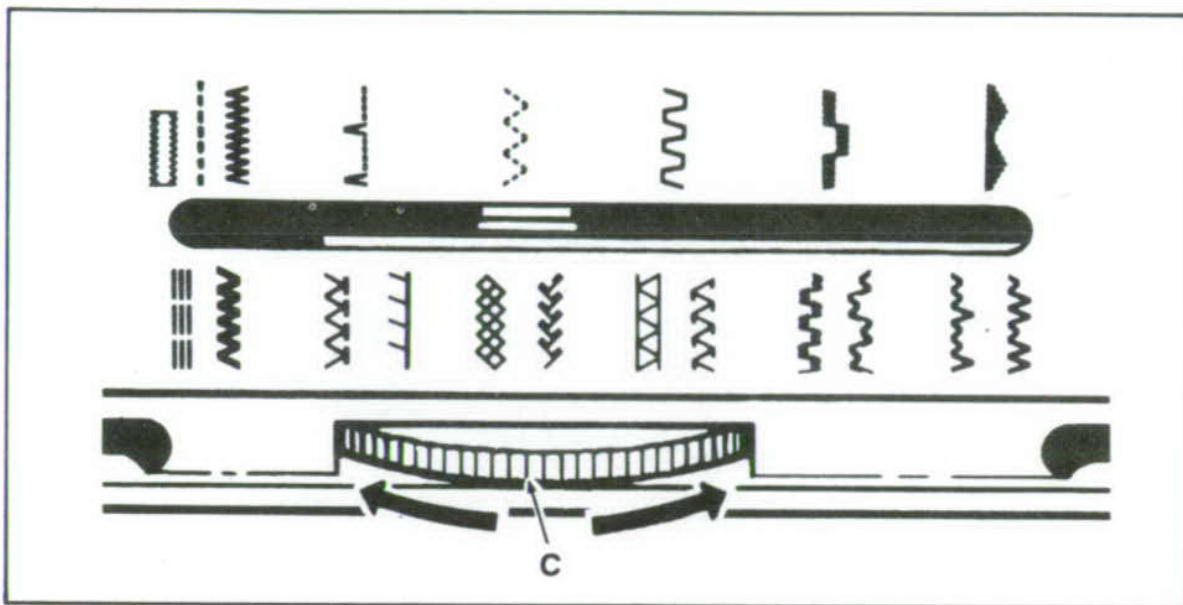

### Selecting a Stitch Pattern

(only 8019)

The stitch pattern selector **D** lets you choose one of the three stitches from the group you have selected. Notice the colour of the stitch you have chosen: (1) green, (2) yellow, or blue/pink (3). To select any pattern, sliding pattern selector until it is aligned with corresponding colour.

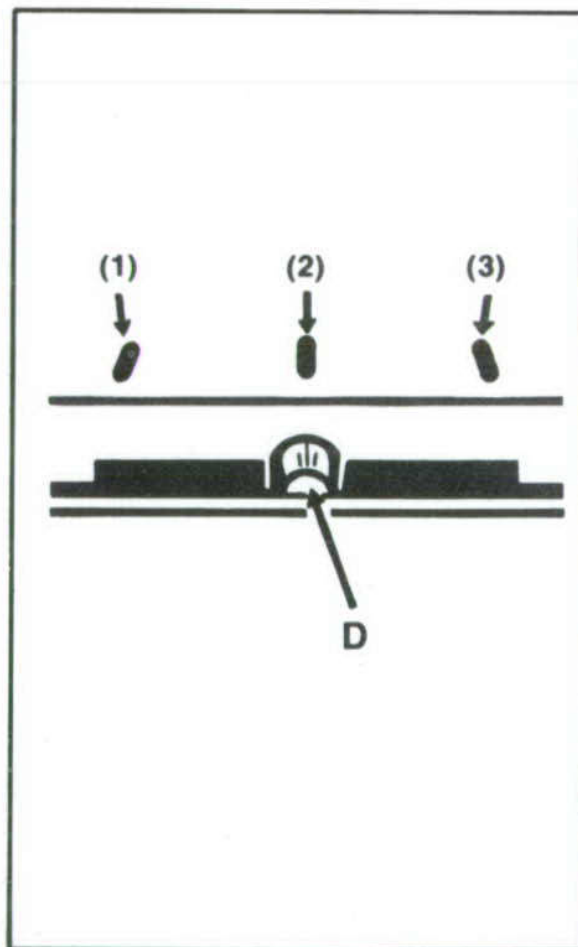

## 1. Adjusting Width Of The Design



*Before moving stitch width selector, always raise needle above fabric.*

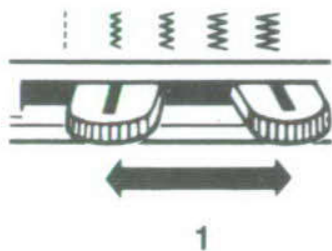





To produce a zig-zag stitch, the stitch width selector must be moved from  toward the right. The further you move the selector lever toward the right, the wider your stitch will be.



## 2. Adjusting Stitch Placement

*Before moving needle position selector, make sure needle is above fabric.*

A needle position selector setting of  places the needle in centre stitching position. Selector settings  and  place the needle in left and right stitching position at stitch width settings narrower than the maximum width.

Selector setting  (centre) is used most often. Settings  (left) and  (right) are for special placement of stitching. For example, a  (left) or setting is used for button sewing. A  (left) or  (right) setting is used to place narrow zig-zag stitching to the left or right of centre in decorative work.

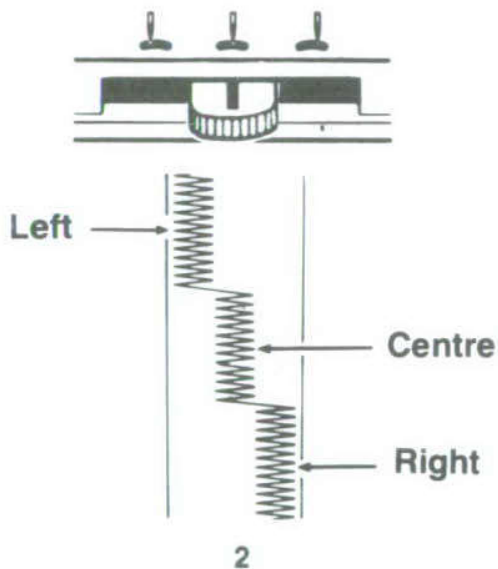

## 3. Adjusting Stitch Length

When you are preparing to do zig-zag stitching, make a test sample with the fabric and thread you plan to use so that you can adjust the stitch length correctly.

Any stitch length setting from 1 to 4 will give you an open zig-zag stitch of whichever *Fashion Stitch* pattern you select. The higher the number, the more open, or farther apart, your stitch will be.

The area between 1 and 0 of the selector is used for the fine adjustment of zig-zag satin stitching. For information on satin stitch length adjustment, see page 25.

For all green or blue Flexi-Stitch patterns, stitch length is controlled with a single setting of the stitch length selector. Simply rotate it until the (Green Blue Pink) mark A is under the triangle above the selector.

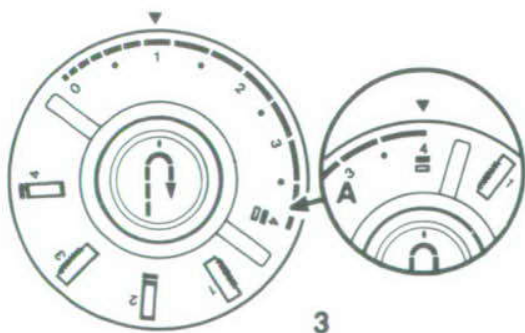

## 4. Adjusting Needle-Thread Tension

When you are preparing to do zig-zag stitching, make a test sample with the fabric and thread you plan to use so that you can adjust the needle-thread tension correctly.

Zig-zag stitching requires less tension than straight stitching. Notice the stitching on your test sample. The stitches should lie flat **B** against the fabric without causing the fabric to pucker. If the stitches are not flat **C** and the fabric is puckering, lower the tension by turning the dial to a lower number.

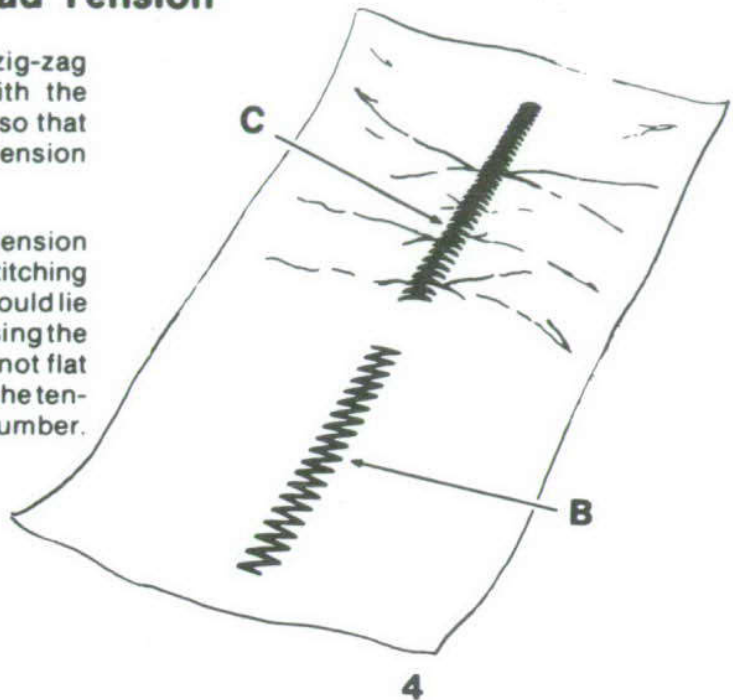
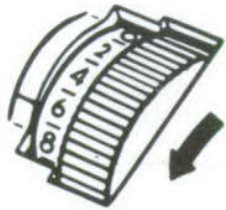



## 5. Adjusting Stitch Balance (only 8019)

When you are using a *Flexi-Stitch* pattern you may need to balance your stitching in order to achieve the correct pattern **D** (see illustration).

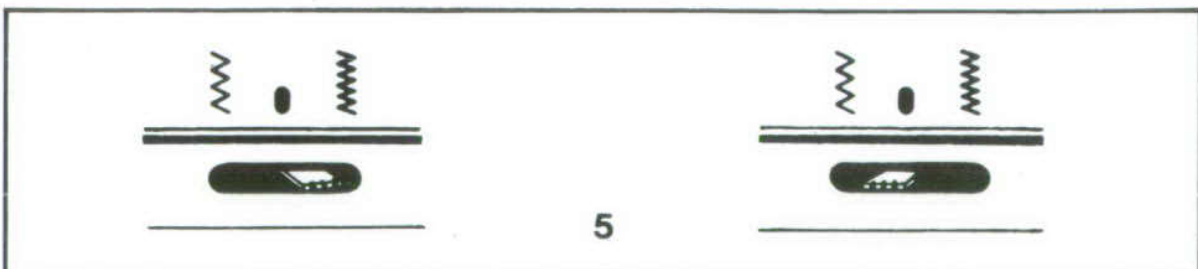
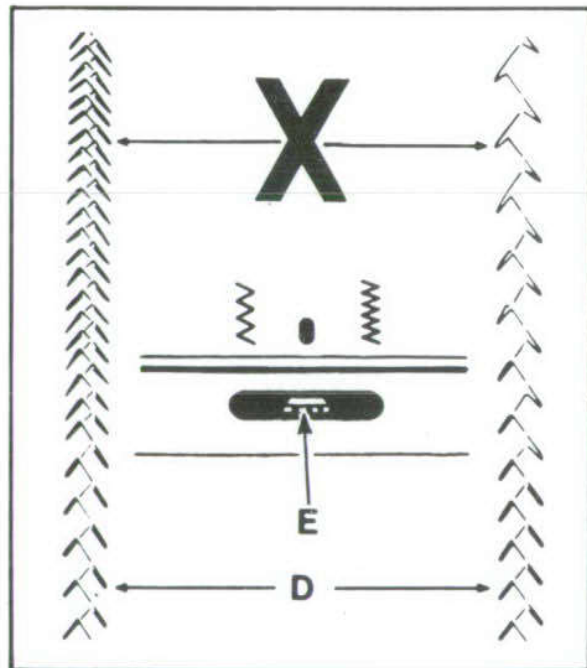
Before you move the stitch balance control lever **E** from its neutral position (lever at center of ●), make a test sample. If adjustment is required, stitch slowly and move the stitch balance control lever as you sew.



- Slide the lever toward  symbol to bring the forward and reverse stitches of the pattern together.

- Slide the lever toward  symbol to separate the forward and reverse stitches of the pattern.

## Satin Stitching

Satin stitching is a series of closely spaced zig-zag stitches that form a smooth satin-like surface. It is useful for both utility and decorative work. Always make a test sample first so that you can adjust the stitch length and thread tension properly.

Soft fabrics may require a backing to ensure firm satin stitching. Crisp organdy and lawn are suitable for this purpose.

- 
- Pattern Group:  Yellow
  - Stitch Width: 
  - Needle Position:   
  - Stitch Length: Between 0 and 1
  - Special Purpose Presser Foot
  - Zig-Zag Needle Plate
- 

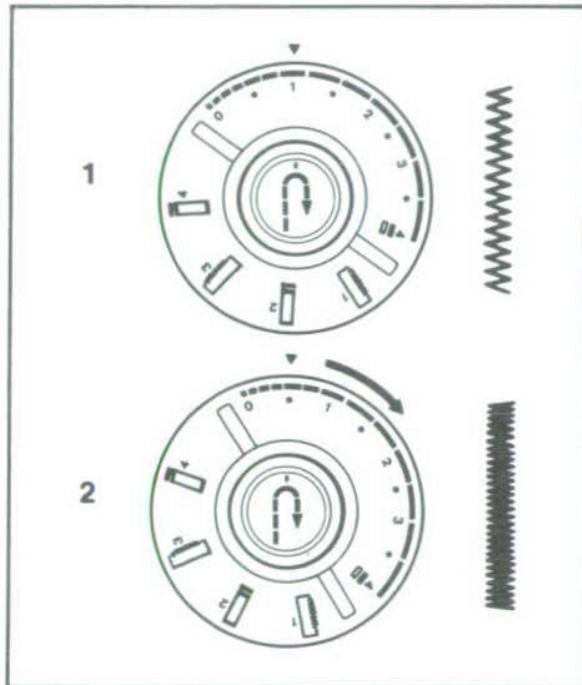

### Adjusting Stitch Length

1. Turn selector dial to 1 and run the machine.
2. While running machine, gradually turn dial toward 0 until stitches are closely spaced and form a smooth satin stitch.

When a smooth satin stitch has been obtained, you may run the machine at any desired speed.

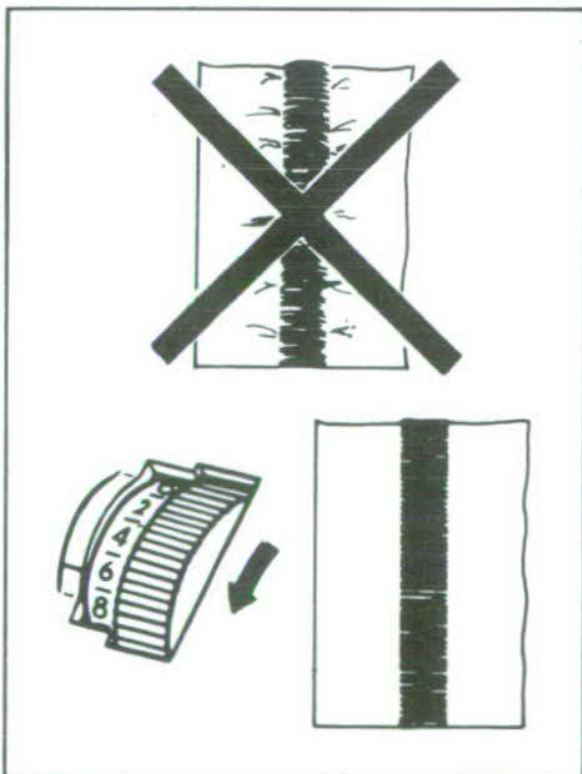

### Adjusting Thread Tension

Satin stitching requires less tension than straight stitching or open zig-zag stitching. Furthermore, the wider the stitch, the lighter the tension on the thread must be.

Notice the stitching on your sample. If the stitching appears to be too tight or the fabric is puckering, lower the thread tension by turning the dial to a lower number.

# 5

## Twin-Needle Stitching

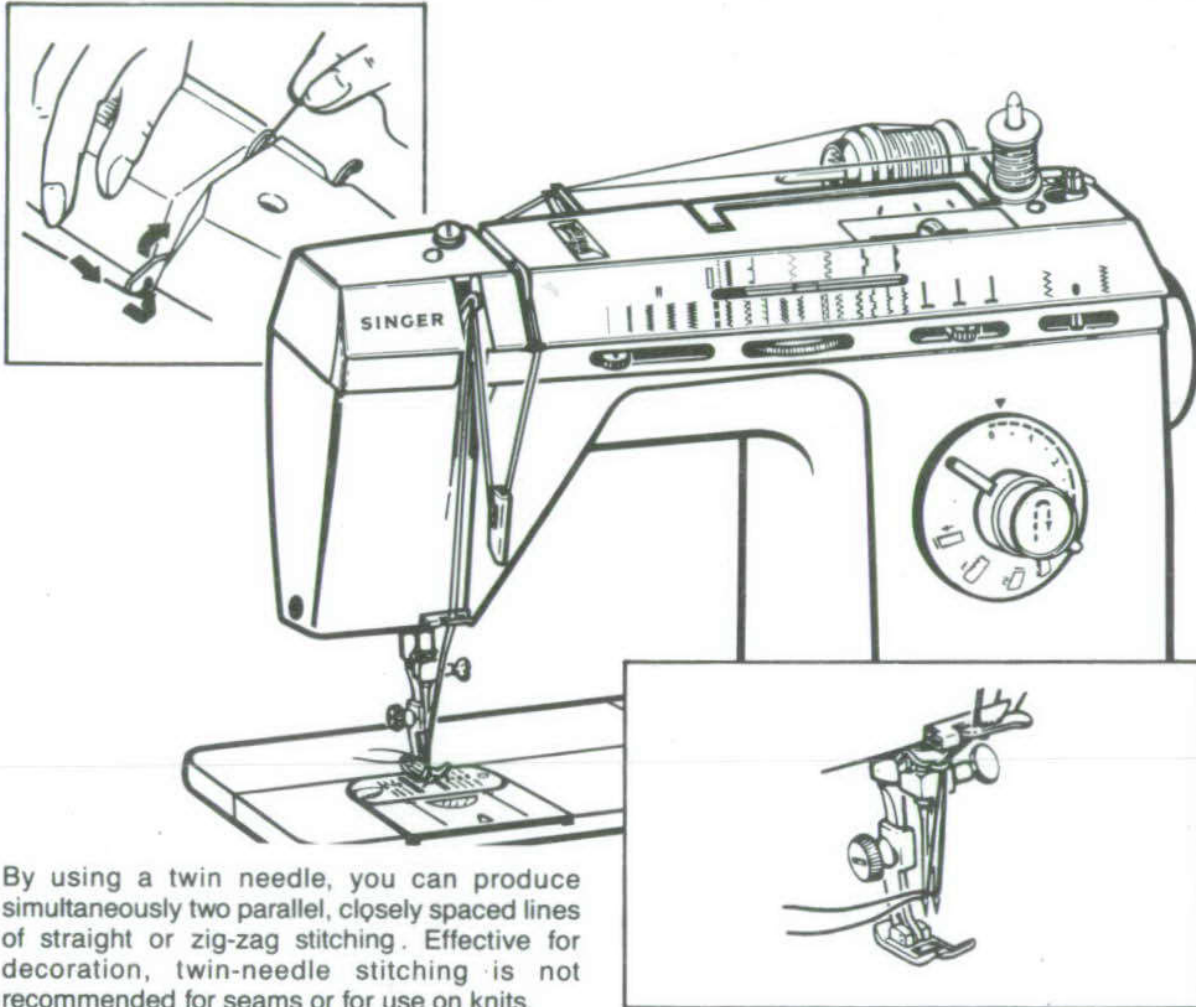

By using a twin needle, you can produce simultaneously two parallel, closely spaced lines of straight or zig-zag stitching. Effective for decoration, twin-needle stitching is not recommended for seams or for use on knits.

Your machine is not supplied with the twin needle or spool pin. These may be obtained from your local SINGER stockist as optional accessories.

Before inserting the twin needle, place the needle position selector at  centre and stitch width selector at  and, remove the single needle.

### *threading the twin needle*

1. Thread machine with first thread from horizontal spool pin as instructed on page 9, making certain thread passes between tension separator and **left-hand** tension disc.
2. Raise presser foot.
3. Insert twin-needle spool pin (optional) into hole provided for it in machine top cover.
4. Pass the horizontal spool pin thread through left **eye of needle**.
5. Place vertical spool of thread on detachable spool pin and thread machine as for one-needle stitching except:
  - Pass thread between tension separator and **right-hand** tension disc. Continue to thread all other threading points.
  - Pass thread through right **eye of needle**.
6. Draw both threads under the foot and back along with the bobbin thread.
7. Slowly lower the needle into the hole in the needle plate by turning the hand wheel toward you to make sure the needle clears the plate.
8. Make sure not to use a stitch width greater than that what is recommended when twin needle stitching.

## machine settings

### Straight Stitching With a Twin Needle

- Stitch Width:
- Needle Position:
- Stitch Pattern: Any Yellow Pattern
- Zig-Zag Presser Foot
- Zig-Zag Needle Plate

### Zig-Zag Stitching With a Twin Needle

- Pattern Group: Any Zig-Zag Pattern
- Stitch Width:
- **Note:** Do not exceed this stitch width setting.
- Needle Position:
- Zig-Zag Presser Foot (open patterns or Special Purpose Foot (satin stitching))
- Zig-Zag Needle Plate

<i>decorative twin-needle stitching</i>				
To produce patterns at right, use settings show below				
<b>Pattern Group Selector</b>	(Blue Pink) 	(Yellow) 	(Yellow) 	(Yellow) 
<b>Stitch Pattern Lever</b>	 (Blue Pink)	 (Yellow)	 (Yellow)	 (Yellow)
<b>Stitch Width †</b>	 ::	 ::	 ::	 ::
<b>Needle Position</b>	  	  	  	  
<b>Stitch Length</b>	(Green Blue Pink)  	1-3	0-1	0-1

†**CAUTION:** Do not use a stitch width greater than what is recommended. A wider stitch will result in needle breakage.

# 6

## Free-Motion Stitching

In free-motion stitching, you sew without a presser foot and control fabric movement by means of an embroidery hoop. Either a straight stitch or a plain zig-zag stitch can be used. Because you can move the hoop in any direction—forward or backward, from side to side, or even diagonally—free-motion stitching is extremely useful for embroidery designs. On the other hand, it is equally useful for darning.

If you are embroidering, you can vary the length of stitches simply by moving the hoop faster or slower under the needle. The faster you move the hoop, the longer the stitches will be. You can also vary the width of zig-zag stitches from wide to narrow by controlling the angle at which the hoop is placed and moved under the needle.

For darning, the embroidery hoop used in free-motion stitching enables you to hold fabric taut—a real advantage when your fabric is lightweight or soft and thus likely to pucker. See page 47 for directions.

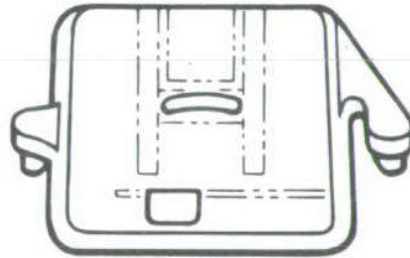
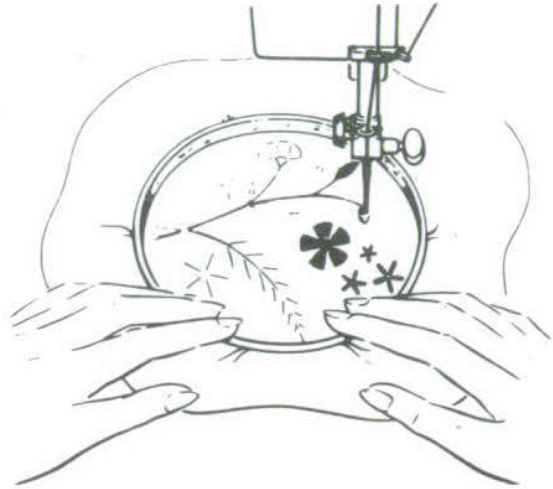

### *preparation*

1. Have available an embroidery hoop designed for machine use, large enough to encompass the entire design, but small enough so that hoop is easily managed.
2. Remove the presser foot.
3. Insert zig-zag needle plate and snap-in feed cover.
4. Rotate stitch length selector dial clockwise to 0.

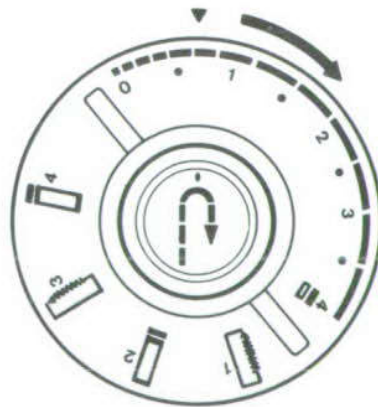

## floral designs

• Pattern Group:  Yellow

• Stitch Width: 

• Needle Position: 

• Stitch Length:

• Presser Foot: None

• Snap-In Feed Cover

• Speed Range: To suit operator

With a little practice on your sewing machine, you will be able to embroider flowers to decorate table linens and other household items, as well as dresses and blouses. If you have designing skill, you will enjoy creating your own designs. Otherwise, you can buy attractive transfer patterns.

To embroider flower designs, prepare the machine and your fabric by following the same steps as for free-motion stitching (page 28).

On your test sample, try out different stitch width settings to determine the one or more best suited to your design.

When filling in outlines, place stitches in parallel lines, shifting the hoop movement as appropriate to the design.

- For a smooth satin stitch that will catch the light, place the parallel stitches close together, moving the hoop slowly and steadily.
- For an irregular texture, move the hoop more rapidly, allowing some stitches to overlap.

A series of bar tacks can be used to form spray-like leaves or flowers.



Flower Design



Bar-Tack Design



Flower, Leaf and Bud Design





























# 7

## Sewing the Professional Way

### sewing knit and stretch fabric

When you sew stretch fabrics, doubleknit, tricot and jersey, choose one of the stretch patterns that sews stretch into the seam. The table below will help you to select the right stitch pattern for your fabric and sew-

ing job. Remember to use a SINGER® ball-point (yellow band) needle, Catalog 2045, in your machine when you sew synthetic knit or stretch fabric.

Stitch Pattern Chart			
Stitch Pattern	Pattern Group	Stitch Length	Where to use
 Straight Stretch†	 (Green)		Heavy-duty construction seams — Seam reinforcement — Dungaree seams — Crotch seams.
 Plain Zig-Zag	 (Yellow)	Optional	General-purpose stretch sewing — Lingerie seams — Attaching stay tape — Seam finishing — Edge finishing — Attaching stretch lace.
 Ric-Rac Stitch	 (Blue, Pink)		Heavy-duty, general-purpose sewing.
 Overedge Stretch Stitch†	 (Green)		Overedge seams that stretch — Crotch seams — Waistband and seam finishes in shorts and slacks — Swimsuit construction.
 Blindstitch	 (Yellow)	Optional	Blindstitch hemming — Overcast seam finishing — Shell hems in lingerie.
 Slant Overedge Stretch Stitch	 (Blue, Pink)		Sweater and swimsuit construction — Overcast seams in bulky knits and stretch terry cloth — Attaching elastic and stretch lace — Edge finishes for seams, hems, and facings.
 Honeycomb Stitch†	 (Green)		Attaching elastic and stretch lace — Lingerie and girdle repair — Swimsuit construction — Edge finishes for seams, hems and facings — Blanket binding.
 Multi-Stitch Zig-Zag	 (Yellow)	Optional	Attaching elastic and stretch lace — Lingerie and swimsuit construction — Girdle seams — Seam finishes — Casings and waistband finishes — Blanket bindings.
 Feather Stitch†	 (Blue, Pink)		Swimsuit seams — Attaching stretch lace — Lingerie and girdle seams — Blanket binding.
 Straight Feather Stitch	 (Blue, Pink)		Ideal for flat-butted seams, and where extra strength is required.

†This stitch is designed for strength and permanence and cannot readily be ripped out without risk of fabric damage

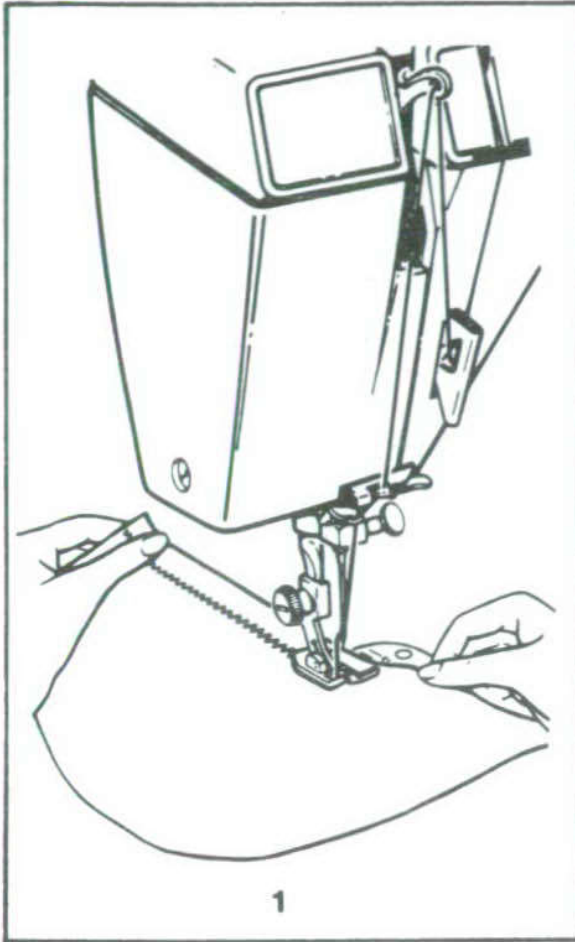

## Guiding and Supporting Fabric

Most fabrics of stretch or knit construction need only to be guided in front of the presser foot. Some fabrics, however, require support while being stitched.



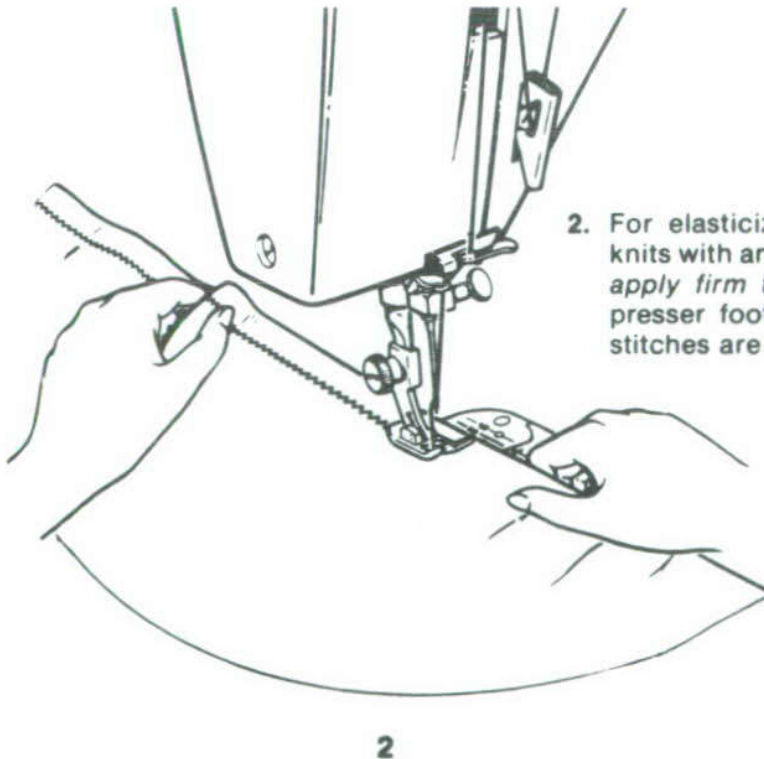

**CAUTION:** Do not pull the fabric as you apply gentle or firm tension while stitching, as this may deflect the needle, causing it to break.

1. For nylon tricot and similar synthetic knits, apply gentle tension by holding fabric in front and back of presser foot as you sew.



2. For elasticized fabric, stretch lace, and knits with an unusual amount of elasticity, apply firm tension in front and back of presser foot to stretch the seam as the stitches are being placed.

## Plain Stretch Seams

- Pattern Group:  (Green)
- Stitch Width: 
- Needle Position: 
- Stitch Length  (Green/Blue/Pink)
- Special Purpose Presser Foot
- Zig-Zag Needle Plate

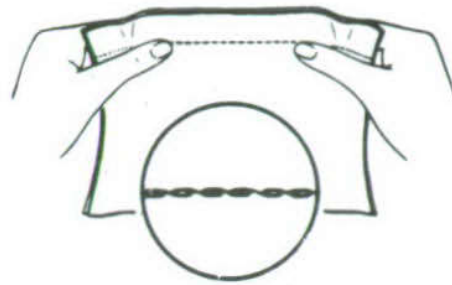

When you use the straight stretch stitch for stress seams or to seam knit stretch, and elasticized fabric, stretch and strength are built into the seam as it is being sewn. *Be sure to insert a ball-point (yellow band) needle, Catalog 2045, in the machine if you are stitching a synthetic knit fabric.*

1. Make a test with a sample of your fabric so that you can adjust thread tension and stitch balance correctly (see page 24).
2. Stitch and guide the fabric as you do for plain seams stitched with the regular straight stitch, letting the machine make the back-and-forth stitches that give stretch to the seam. If the fabric has an unusual amount of elasticity, it should be guided and supported as instructed on page 31.
3. After stitching, press seam as when using the regular straight stitch.

## Lingerie Seams

- Pattern Group:  Yellow
- Stitch Width: 
- Needle Position: 
- Stitch Length: To suit fabric
- Zig-Zag Presser Foot
- Zig-Zag Needle Plate

To make a lingerie seam both durable and flexible, use a zig-zag stitch. This treatment is particularly suitable for bias seams.



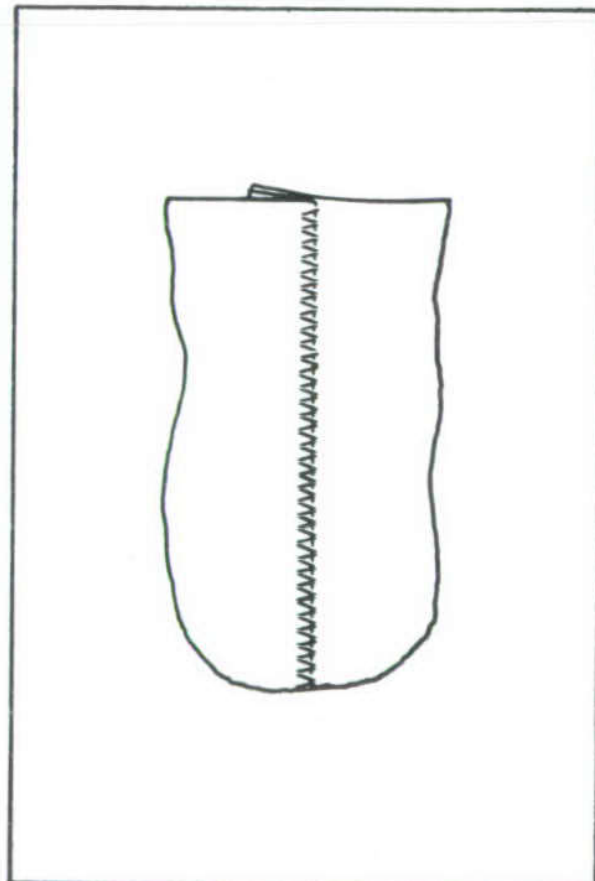



1. Straight-stitch the seam (with stitch width selector at ) on the wrong side.
2. Press both seam allowances in the same direction.
3. From the right side, top-stitch with zig-zag pattern, letting the needle alternately enter the seam line and seam thickness.

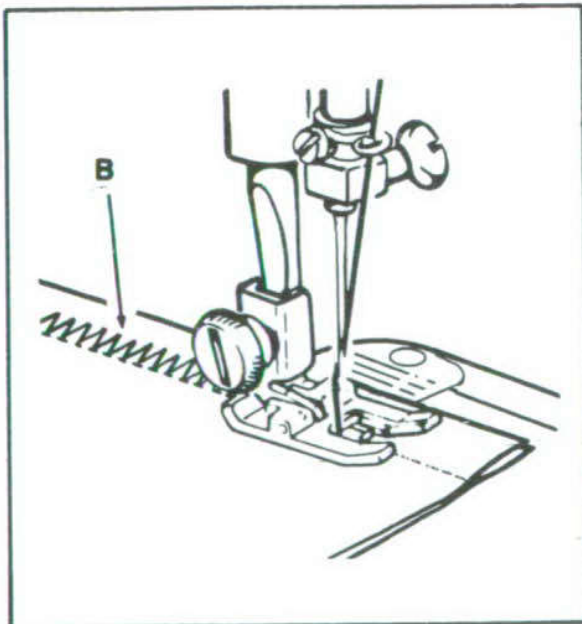
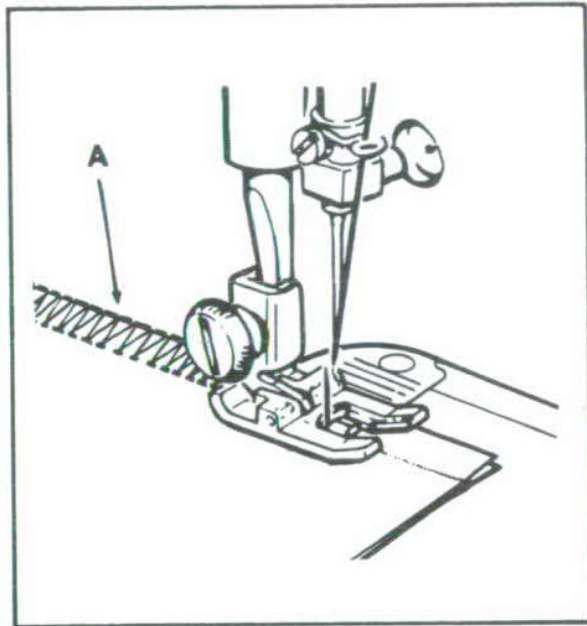

## Overedged Seams

Seams in knit and stretch fabric can be joined and finished in one operation. Two different methods may be used. Method No. 1 is recommended for firm fabrics where a 6mm (1/4") seam allowance is adequate. Method No. 2 is recommended for bulky knits and fabrics that have a tendency to curl or fray and where a wider seam allowance is needed for support. Make a test sample to help you decide which method is best for your fabric and garment. *Remember to use a Catalog 2045 ball-point (yellow band) needle if you are sewing a synthetic knit.*



- 
- Pattern Group:  (Green)
  - Stitch Width:    
  - Needle Position:   
  - Stitch Length:  (Green/Blue/Pink)
  - Special Purpose Presser Foot
  - Zig-Zag Needle Plate
- 

### Method No. 1 — Overedging

1. Cut and fit the garment, allowing for a 1.6cm (5/8") seam allowance. Baste seam line.
2. Trim seam edge evenly to a scant 6mm (1/4") from seam line basting.
3. Place seam under the presser foot so that the straight stitches fall on the basted seam line and zig-zag stitches toward the seam edge **A**, as illustrated.

### Method No. 2 — Mock Overedging

1. Cut and fit garment, allowing for a 1.6cm (5/8") seam allowance. Baste seam line.
2. Place seam under presser foot so that the straight stitches fall on the basted seam line and zig-zag stitches toward the seam edge **B**.
3. Press after stitching and trim away excess fabric to produce a narrow seam edge. When seam supports the garment, omit the trimming step.

## Attaching Elastic

- Pattern Group:  (Green) (Blue/Pink) or  (Yellow)
- Stitch Width: 
- Needle Position: 
- Stitch Length: Approx. 1.5 (for Yellow pattern) or (Green/Blue/Pink) 
- Zig-Zag Presser Foot and Needle Plate

### To Attach Waistline Elastic

- Fit elastic for desired snugness at waistline, allowing 1 inch (2.5cm) for joining. Lap ends to form a band and straight stitch together as shown using a ball point needle.
- Divide elastic band into four equal segments and mark with pins. Do the same to the garment. Then pin together at corresponding points, pinning elastic over right side of fabric, top edges even.
- Sew a few straight stitches to anchor elastic to fabric.

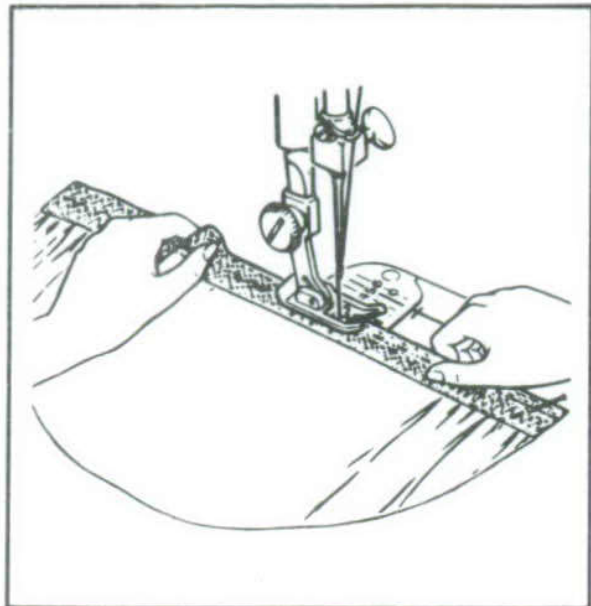

- Select honeycomb.
- Then hold elastic and garment edge taut as you stitch so that it will remain stretchable after stitching is completed.

**CAUTION:** Do not pull the fabric while you are stitching as this may deflect the needle, causing it to break.

## Finishes For Hems And Facings

- Pattern Group:  (Green) or  (Yellow)
- Stitch Width: 
- Needle Position: 
- Stitch Length: to suit fabric and stitch
- Special Purpose Presser Foot
- Zig-Zag Needle Plate

- Make a test sample first.
- Place stitching about 3mm (1/8") in from hem or facing edge.
- Press after stitching and trim away excess fabric close to the stitching line.

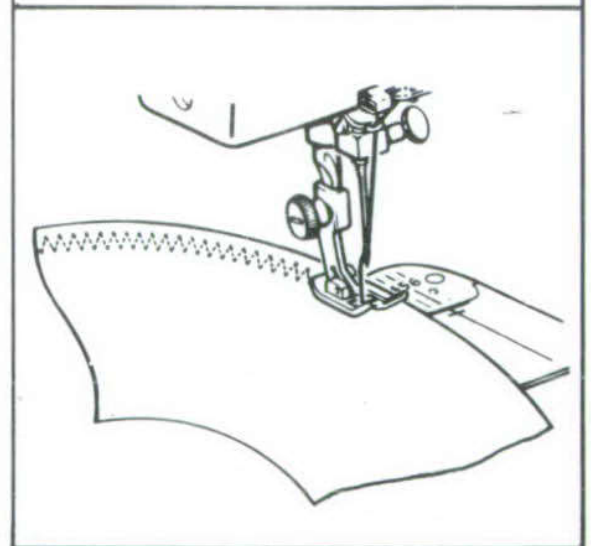
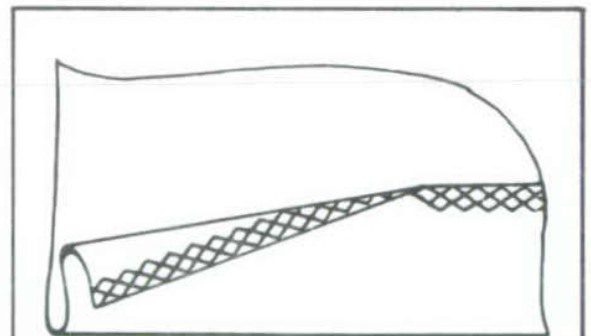

## handling special fabrics

Many fabrics because of their construction or finish, demand special attention in sewing. Techniques used in stitching and handling, and choice of machine accessories, will vary with the fabric. Let the table below guide your selection.

Fabric Handling Table				
Fabric	Special Handling	Stitch Length-type	Needle Style-Size	Machine Accessories
<b>Vinyl</b> - leather-look, patent, suede, reptile	Use transparent tape as a substitute for pins or basting—Topstitch to hold seams and edges flat—Avoid worked (machine buttonholes. Use bound buttonholes.	Long Straight-Stitch	Style 2020 Size 14 or 16 for woven backing Style 2045 Size 14 or 16 for knit backing	General Purpose Foot† General Purpose Needle plate
<b>Pile</b> - velvet, velveteen, corduroy	Stitch in direction of nap—Use plain seams—Zig-Zag or bind seam edges to prevent fraying—Press over a self-fabric cloth.	Medium Straight Stitch for seams Medium Zig-Zag or Honeycomb stitch for overcasting	Style 2020 Size 14 Style 2045 Size 14 or 16 for panne' velvet	General Purpose Foot† (General Purpose Foot only for overcasting) General Purpose Needle plate
<b>Deep Pile</b> - fake fur, percale, broadcloth, shirting	Pin rather than baste seams—Stitch in direction of nap—Use plain seams for short-hair furs; narrow over-edged seams for shaggy, bulky furs —Shear pile from seam allowances to reduce bulk.	Long Straight Stitch for plain seams Medium to Short Zig-Zag Stitch for over-edged seams	Style 2020 Size 16	General Purpose Foot† General Purpose Needle plate
<b>Permanent Press</b> - percale, broadcloth, shirting	Control seam tension manually by holding fabric taut as it passes under the presser foot. Sew at moderate speed.	Medium Straight Stitch	Style 2020 Size 11 or 14	Straight Stitch Foot and Needle Plate
<b>Fine Knits</b> - tricot, jersey	Use narrow overedged, double stitched, or French seams—Hold thread ends securely for a few stitches at start of seam—Support seams while stitching.	Medium Straight Stitch Medium to Short Narrow Zig-Zag or Narrow Overedge	Style 2045 Size 11 or 14	Straight Stitch Foot and Needle Plate (for straight stitching) General Purpose Foot and Needle Plate (for zig-zag stitching)
<b>Blanket Binding</b> - satin face	Hand-baste binding to blanket (pin marks show) — Miter corners.	Long Straight Stitch Medium to Long Zig-Zag Stitch or Decorative Stitch	Style 2020 Size 11 or 14	General Purpose Foot† General Purpose Needle plate
<b>Soft Sheer</b> - chiffon, voile, China silk	Use French seams, double stitched —Hold ends of upper and lower thread when you begin to stitch —Support fabric while stitching.	Medium to Short Straight Stitch	Style 2020 Size 9 or 11	Straight Stitch Foot and Needle Plate
<b>Napped Fabric</b> - cashmere, mohair, camel hair	Cut with nap running down—Sew in direction of nap—Topstitch to hold seams and edges flat.	Medium to Long Straight Stitch	Style 2020 Size 11 or 14	General Purpose Foot† General Purpose Needle plate

† For best results when sewing this fabric, we recommend use of the Even Feed Foot, available at your Sewing Centre.

## construction details

### Zipper Insertion

How the zipper is inserted will depend on the type of the garment and the location of the zipper. With the adjustable zipper foot, you will find it easy to sew an even line of stitching close to the zipper. For inserting the zipper foot on machine see pages 4 and 7.

• Pattern Group:  Any Yellow Pattern

• Stitch Width:     

• Needle Position:   

• Stitch Length: To suit fabric

• Zipper Foot

The zipper foot can be used either to the left or right of the needle—depending on where the bulk of the garment is placed.

#### Attaching the Zipper Foot

When the zipper foot is to the right of the needle:

- Attach left side of zipper foot to shank (needle will enter left notch in foot)—see illustration **A**.

When the zipper foot is to the left of the needle:

- Attach right side of zipper foot to shank (needle will enter right notch in foot)—see illustration **B**.

#### Zipper Inserted under left Lapped Seam

- Baste the seam line the exact length of the garment opening and press the seam open.
- Attach the zipper foot to the right of the needle (illustration **A**).
- Open the zipper.
- Flatten out the back seam allowance and place the zipper face down on it, as illustrated, with the edge of the zipper teeth following the seam line.
- Stitch the zipper tape onto the seam allowance.
- Adjust the foot to the left of the needle (illustration **B**).
- Close the zipper and turn it face up.
- Smooth back the seam allowance at the edge of the zipper.
- Top stitch to the tape close to the folded edge.
- Spread garment flat and turn zipper face down over front seam allowance.
- Hand baste zipper to garment from wrong side, through zipper tape, seam allowance, and front of garment.
- Turn garment right side out.
- Adjust zipper foot to right side of needle and stitch across the lower end of the zipper and up to the waistline, using the basting stitches as a guide.
- Remove bastings. Press.

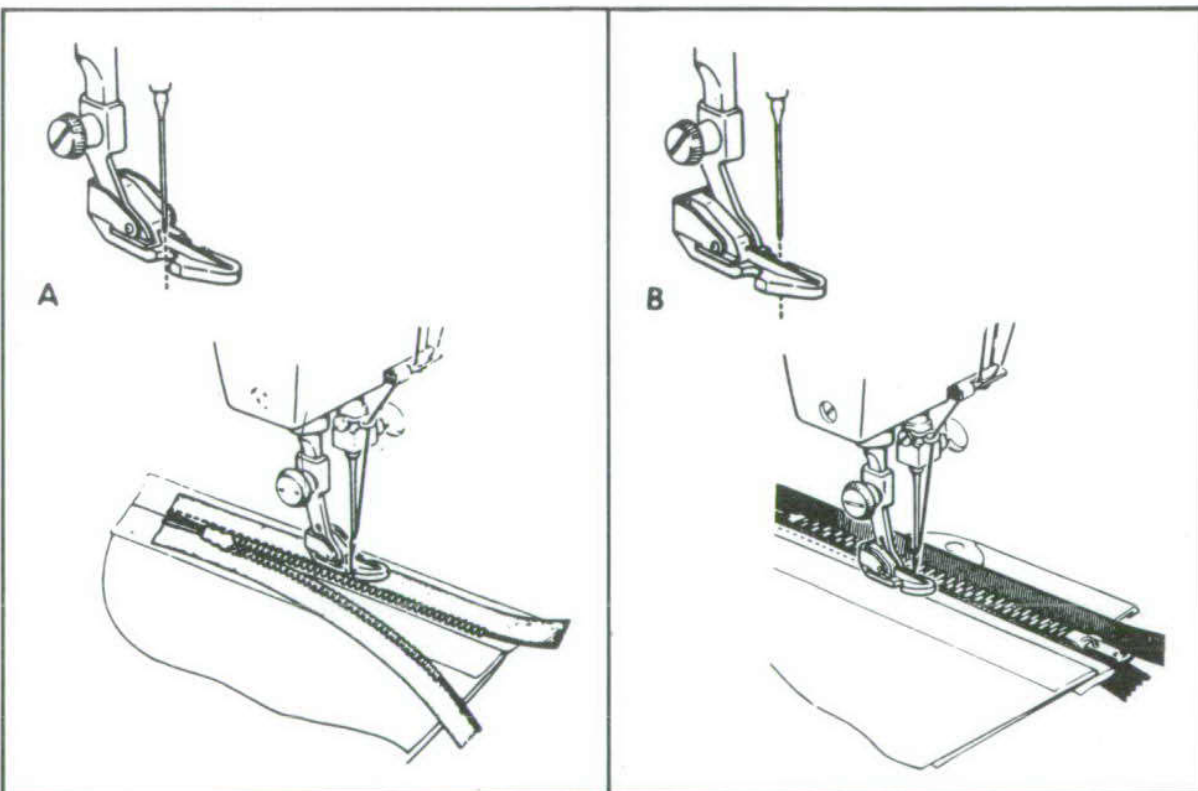

## Corded Seams

The corded seam is a professional treatment for slipcovers, children's clothes, blouses, and lingerie. To make a corded seam, make the welting first (or buy it ready-made), then stitch it into the seam. For both steps, use the following settings and accessories:

- Pattern Group:  Yellow
- Stitch Width: 
- Needle Position: 
- Stitch Length: Slightly longer than for regular seaming
- Zipper Foot
- Zig-Zag or Straight Stitch Needle Plate

### 1. Making the welting

1. Buy cable cord (at a notions counter) of desired size.
2. Cut bias strips of fabric (width: three times the diameter of the cord plus 3cm (1-1/4")).
3. Sew strips together on the lengthwise grain to obtain desired length.
4. Fold resulting strip over cord with raw edges even.
5. Attach zipper foot to the left of the needle. (For instructions on attaching zipper foot, see page 36).
6. Lower the presser foot.
7. Stitch close to the cord (but do not crowd stitching against cord), pulling gently on the strip, both in front and in back of the zipper foot.

### 2. Stitching welting into seam

1. Attach zipper foot to the right of the needle so that the bulk of the fabric will fall to the left.
2. Stitch welting to the right side of a single seam edge; guide the edge of the foot next to the cord but do not crowd.
3. Place the attached welting over the second seam edge, and pin or baste together.
4. Place the work under the needle, with the first stitching on top so that you can use it as a guide.
5. Stitch, this time crowding the foot against the cord.

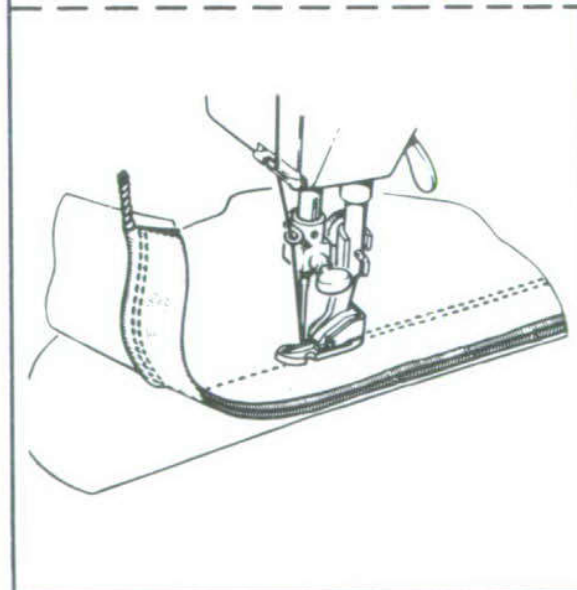
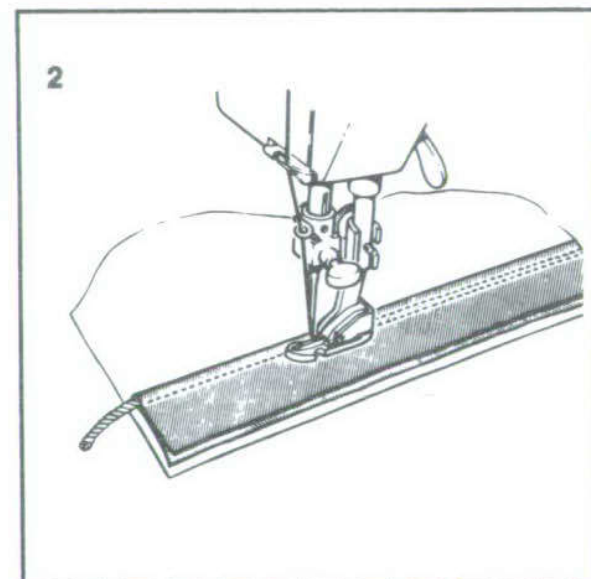
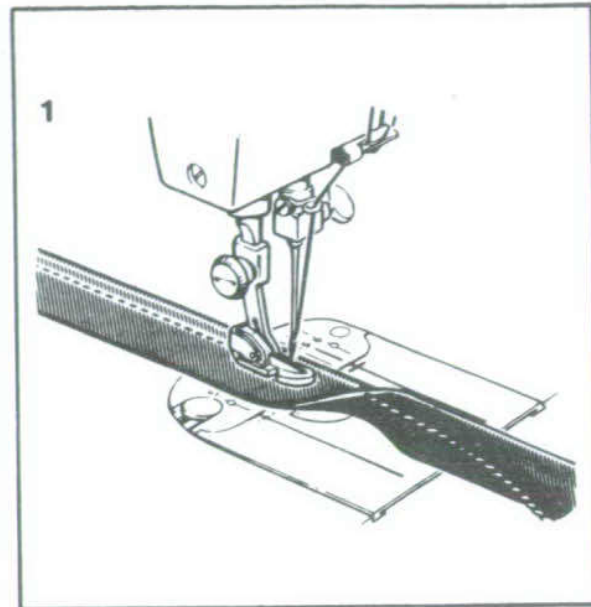



## Blindstitch Hems (only 8007 and 8019)

Blindstitching provides a durable hem finish that is almost invisible. It is best suited to straight hems. Taped, bound, turned, or unfinished hem edges can be blindstitched with equal ease. Blindstitching takes a little practice, however, so make a test sample first.

- 
- Pattern Group:  Yellow
  - Stitch Width: To suit fabric
  - Needle Position: 
  - Stitch Length: 1 to 2.5
  - Zig-Zag Presser Foot
  - Zig-Zag Needle Plate
  - Blindstitch Hem Guide
- 

1. Mark, turn, and press hem in the usual way.
2. Baste a guideline at least 1.3cm (1/2") from the top edge of the hem so that the basting will not be caught by the flange of the blindstitch hem guide.
3. Attach the blindstitch hem guide to the presser bar (see Page 5).
4. With the work wrong side up and the bulk of the fabric to the left, turn the hem under, creating a soft fold about 6mm (1/4") from top edge of the hem.
5. Position the hem under the presser foot with the flange on the front of the guide resting on the 6mm (1/4") hem edge and the soft fold against the wall of the flange.
6. Stitch so that straight stitches fall on the hem edge and the sideward stitches pierce the soft fold. While stitching, feed the soft fold against the wall of the flange and guide the hem edge in a straight line.

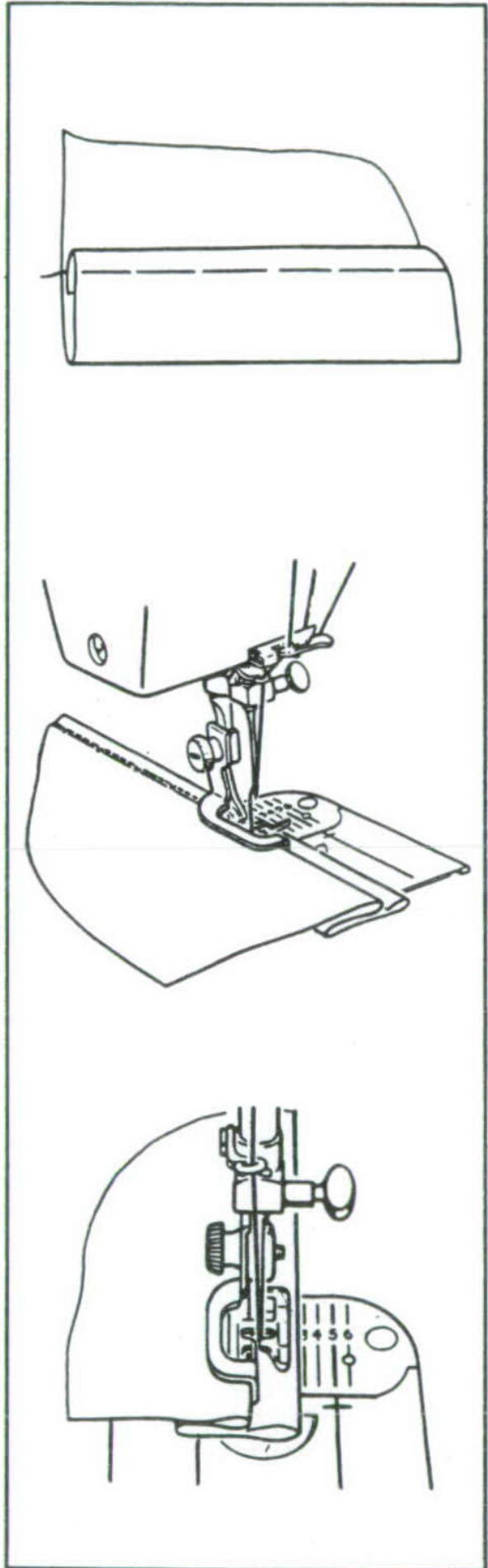

## buttons

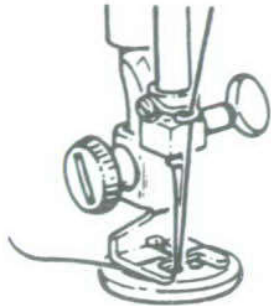
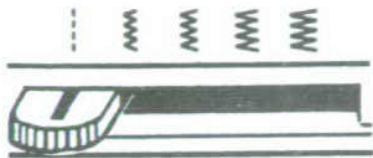

1

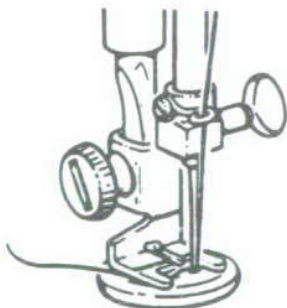
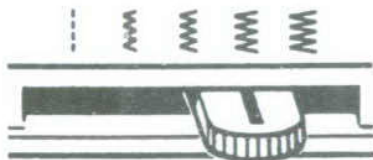

2

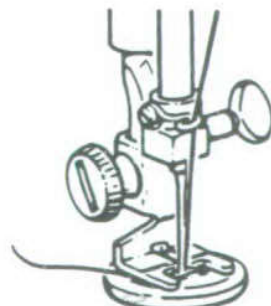
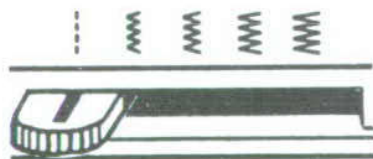



3

- Pattern Group:  Yellow
- Stitch Width: To suit button
- Needle Position:   
- Button Foot
- Snap-In Feed Cover

Flat buttons can be sewn on quickly and easily using the plain zig-zag stitch.

The space between the holes in the button determines stitch width settings.

- Attach snap-in feed cover to zig-zag needle plate.

1. Set stitch width at  and needle position selector at . Position button under foot and lower the needle into the center of the left hole. Lower the foot. Turn hand wheel toward you until needle rises out of button and is above the foot.

2. Move stitch width selector until needle is over the other hole in the button. Continue turning hand wheel until the needle is above right hole, adjust stitch width, as necessary, until needle enters center of the right hole. Take six or more zig-zag stitches and finish with the needle on the left side.

3. To fasten stitching, adjust stitch width to  and take three or four stitches.

- Remove work, draw threads to underside of fabric, fasten, and trim.

## buttonholes

You have a choice between two methods of making bar-tack buttonholes; using the built-in four-step system, or manually controlling the selectors.

On pages 41 and 43 you will find detailed instructions for using the two methods; but you will find the following information basic to both.

1. Always make a test buttonhole on a sample of your fabric. Be sure to duplicate the thickness of the garment. Include interfacing if appropriate.
2. Use No. 50 or finer mercerized cotton thread or embroidery thread, and reduce needle-thread tension to slightly less than normal.
3. Use a size 11 needle for embroidery thread and a size 14 needle for mercerized cotton thread.

### Buttonhole Position

Accurate guidelines are essential to keep buttonholes **A** at a uniform distance from the edge of the garment, evenly spaced, and on the grain of the material.

Mark the centre line **B** of the garment. This guideline can be made by hand basting. The space from the centre line to the finished edge of the garment **C** must be from 1.9cm (3/4") to the full diameter of the button. **D** With this spacing, the button will not extend beyond the edge when the garment is buttoned. Make sure the centre line marking follows a lengthwise fabric thread.

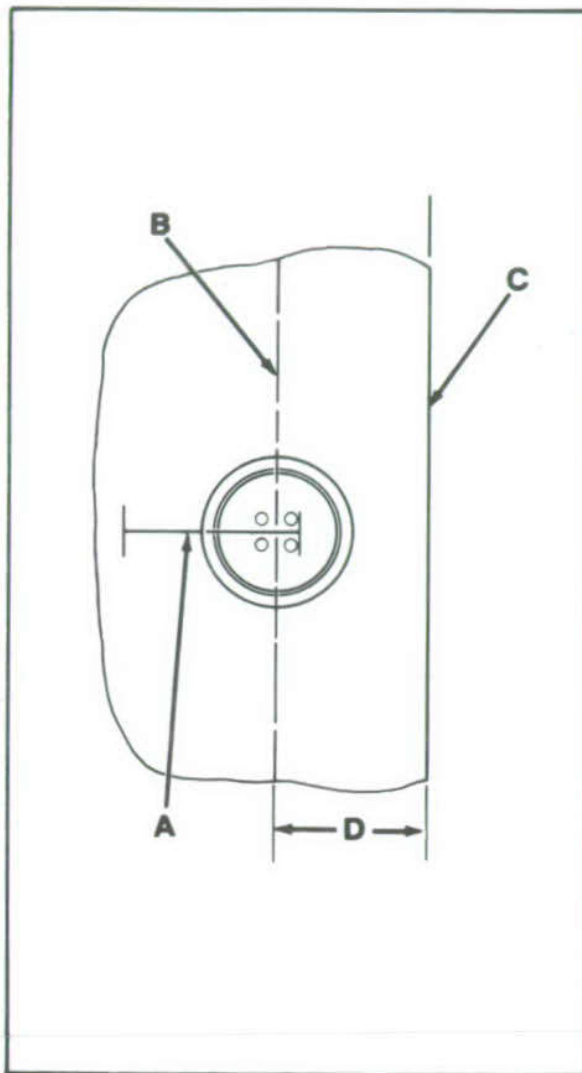

### Marking the Garment

- Mark a position guideline with hand basting for each buttonhole.
- Horizontal buttonholes **1** are placed to extend 4mm (1/8") beyond the centre line of the garment **E**, as illustrated, so that buttons will be in the centre of the figure when the garment is fastened. Horizontal buttonhole guidelines should follow a crosswise fabric thread and should be longer than the finished length of buttonhole. Mark ends of buttonhole vertically.
- Vertical buttonholes **2** are placed on centre line of garment **E**, as illustrated. Mark ends of buttonhole horizontally across the centre line basting and use the centre line marking as the buttonhole guide when stitching.

Spaces between buttonholes should be equal. When a line of buttonholes crosses the waistline, be sure that one buttonhole will fall exactly on the waistline. Then measure the other buttonhole markings from that point.

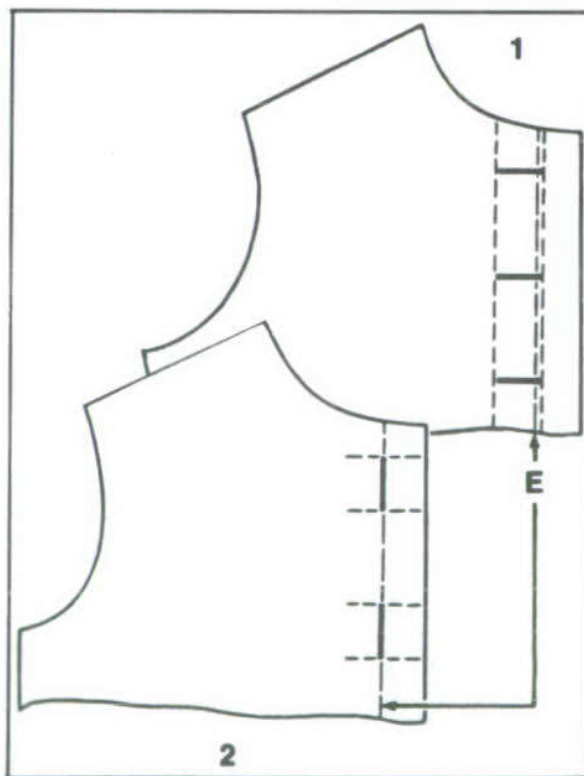

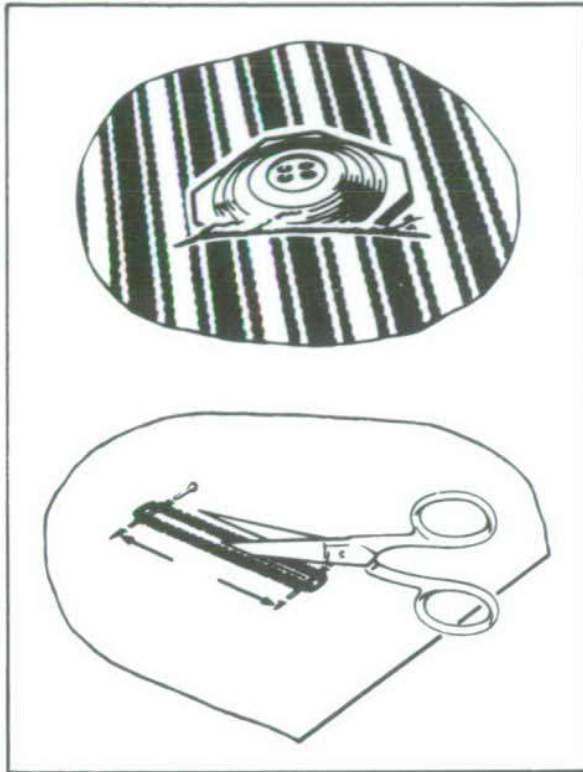

## Buttonhole Length

A buttonhole length should be just long enough to allow the button to slip through the opening without stretching. You can estimate the proper buttonhole length by measuring the width plus the thickness of the button. To make sure the measurements is correct, cut a slit in a scrap of fabric the diameter of the button you intend to use. Increase length of opening until button slips through easily. This test is particularly advisable for buttons of unusual shape or thickness.

## Cutting Button Opening

Place a pin across the cutting space at each end of the buttonhole to protect the end stitching. Use a pair of small sharp scissors to cut button opening. Insert blade in center of cutting space and cut from this point in either direction.

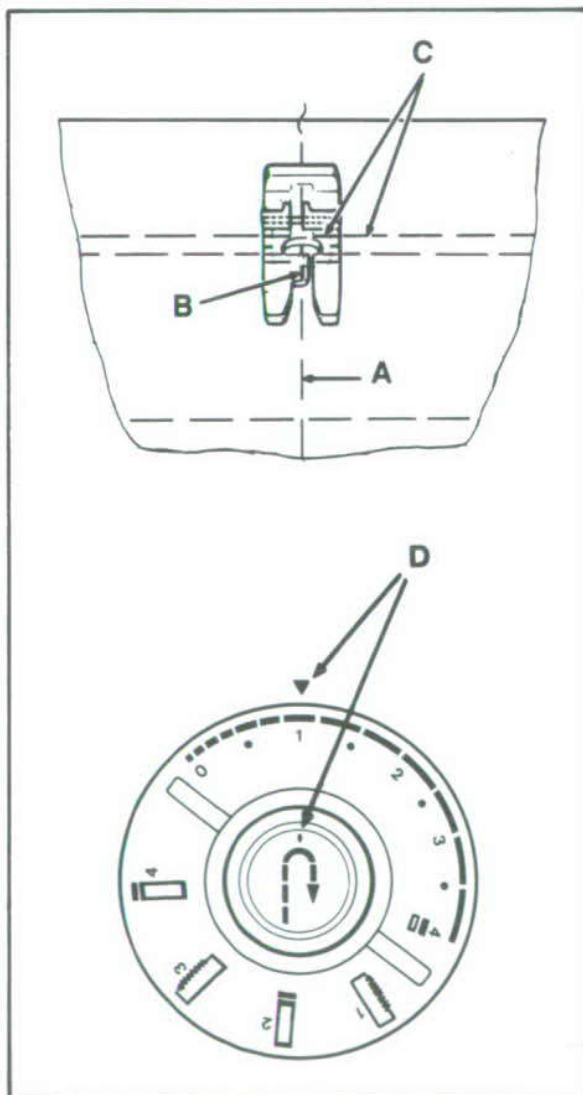

## Four-Step Buttonholing (only 8007 and 8019)

The four dial settings for buttonholing are located on the opposite side of the stitch length selector. As you turn the dial for each step, your machine is automatically set for the correct needle position, stitch width, and stitch length, as well as for stitching direction for that step. You need not turn the fabric during buttonholing.

- Pattern Group:  Yellow
- Buttonhole Foot
- Zig-Zag Needle Plate

### Procedure:

- Follow the instructions beginning on page 40 for preparing and marking the garment.
- Raise the needle above the fabric.
- Position the work under the buttonhole foot aligning centre marking **A** of buttonhole with centre red line **B** on the foot.
- Align end marking **C** of buttonhole with the horizontal red lines on the foot.
- Set reverse-stitch push button in neutral position **D**. Adjust if necessary to equalize difference in stitch density between left and right side of test buttonhole. Turn to page 43 for detailed instructions.

### Step 1: Side Stitching

With the needle raised above the fabric, turn the buttonhole dial clockwise to step 1. Position needle in fabric at point **A**. Lower the foot and stitch to end of buttonhole (point **B**). The end marking should be aligned with the horizontal red lines on the foot.

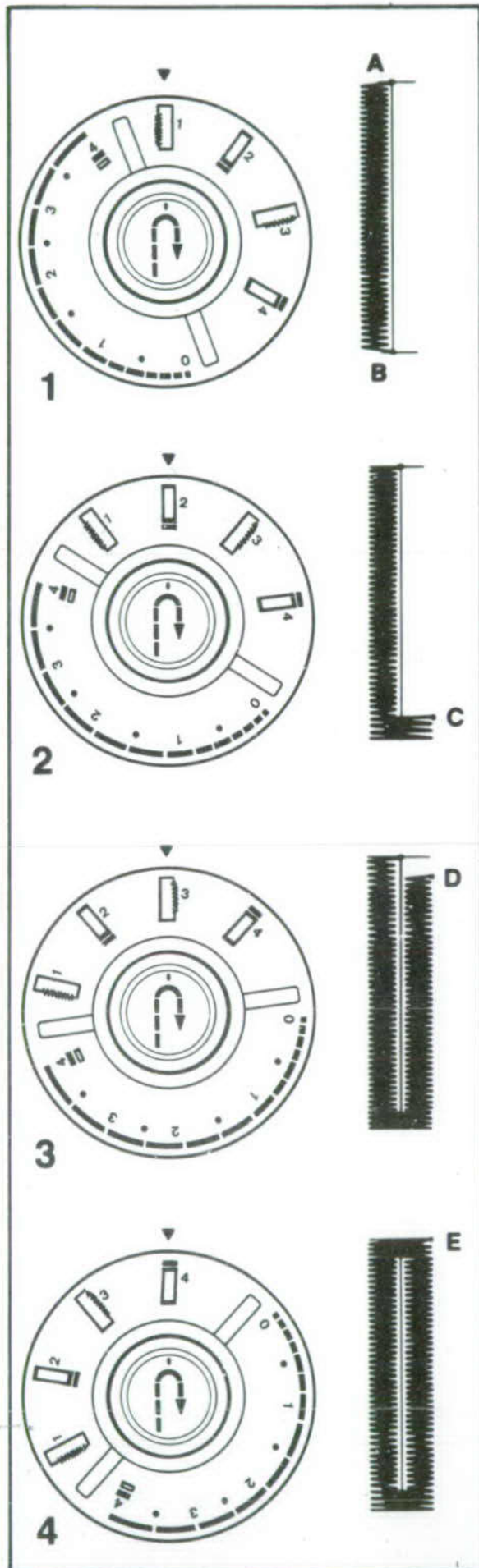

### Step 2: Bar Tack

Raise the needle above the fabric. Turn buttonhole dial counterclockwise to step 2. Take about six stitches to point **C**.

### Step 3: Side Stitching

Raise the needle above the fabric. Turn buttonhole dial counterclockwise to step 3. Stitch to within two stitches of the end of the buttonhole (point **D**).

### Step 4: Bar Tack

Raise the needle above the fabric. Turn buttonhole dial counterclockwise to step 4. Take about six stitches to point **E**. For a smooth, satin appearance and greater durability, stitch around the buttonhole a second time by repeating the four-step sequence.

Remove the work, draw threads to the underside, tie, and trim. Cut button opening with sharp scissors as instructed on page 41.

When buttonholes are completed, rotate dial counterclockwise to stitch length settings to set machine for regular stitching.

## Adjusting Forward-Reverse Stitch Balance

Difference in stitch density between the left and right sides of the buttonhole (forward and reverse stitching) are equalized by adjusting the reverse-stitch push button. A very slight rotation of the button will produce a noticeable change.

1. Make a test buttonhole with the push button in neutral position (indicator dot directly below ▼ symbol on control panel).
2. If the stitches on the left side of the buttonhole are too open, rotate the push button clockwise from its neutral position to increase density of stitching.
3. If the stitches on the right side of the buttonhole are too open, rotate the push button counterclockwise from its neutral position to increase density of stitching.

After buttonhole stitching is completed, return push button to its neutral position (indicator dot directly below ▼ symbol on control panel).

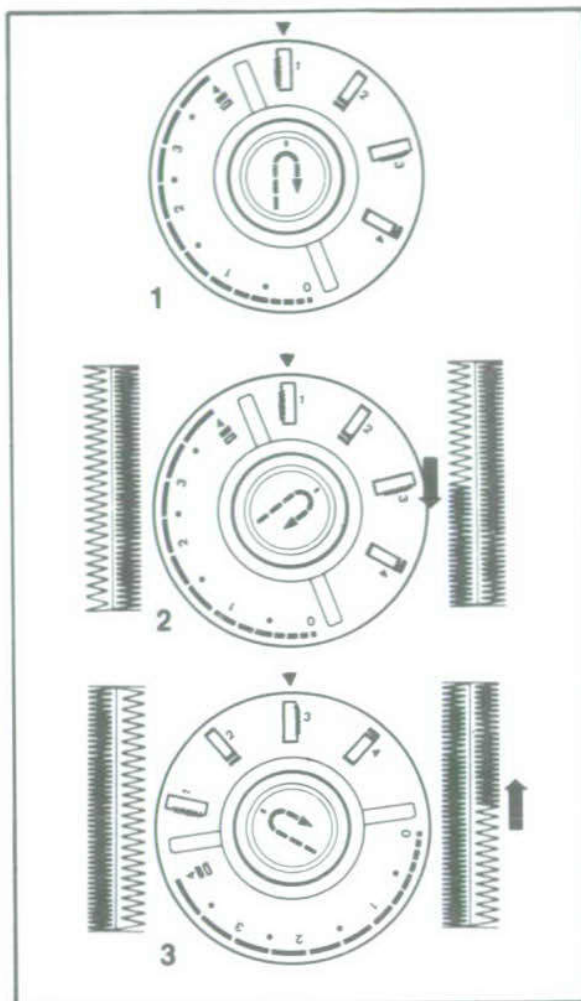

## Buttonholes (Manual Method) Settings

- Pattern Group:  Yellow
- Stitch Width: See Below
- Needle Position: 
- Stitch Length: Between 0 and 1
- Special Purpose Presser Foot
- Zig-Zag Needle Plate

Always make a test buttonhole on a sample of your fabric. Be sure to duplicate the thickness of the garment and include interfacing if appropriate.

Follow the instructions beginning on page 40 for preparing and marking the garment.

### Stitch Width Settings

You will use two stitch width settings: one for side stitching **A** and one for the bar tacks **B** (the closing at each end of the buttonhole). These stitch widths may vary according to the size of the buttonhole required. Two possible combinations are illustrated at the right.

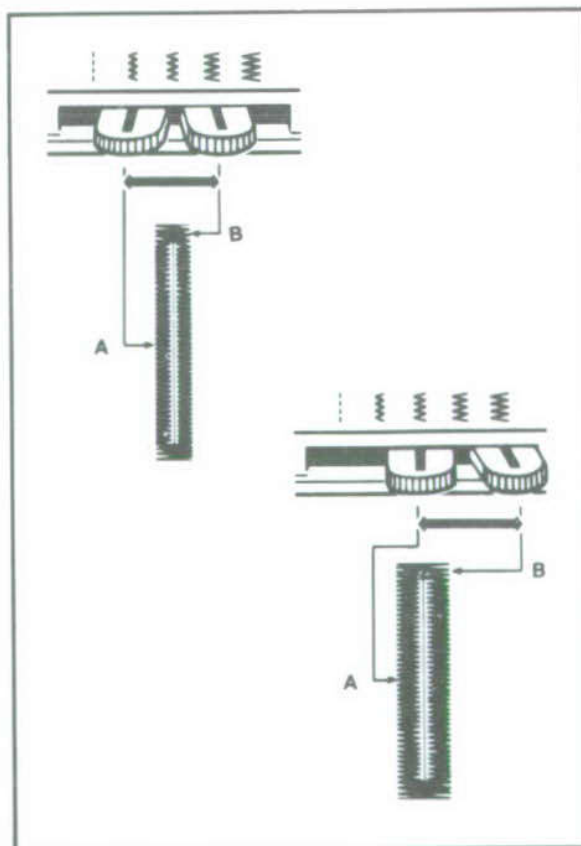

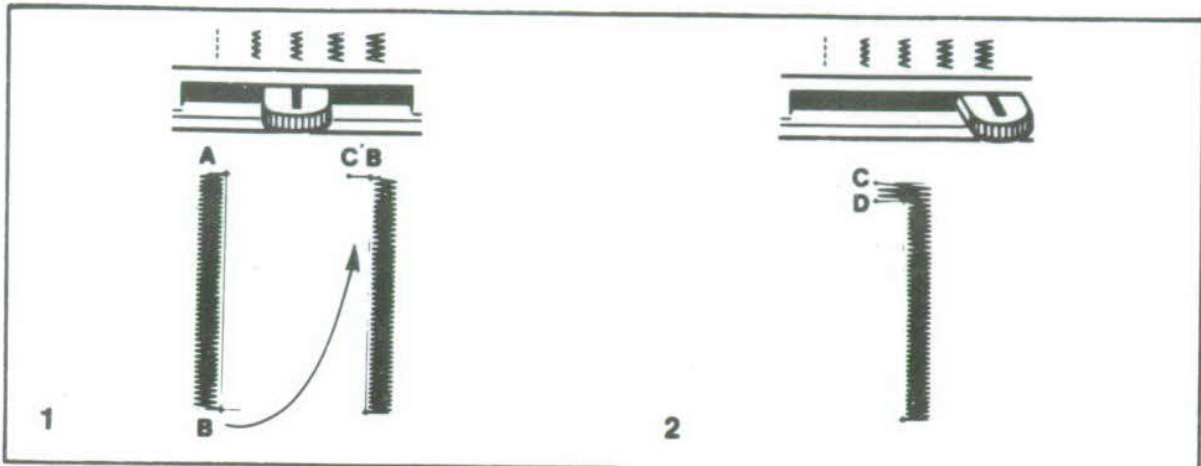

## Procedure

Place work under needle, aligning centre marking of buttonhole with the black line in the center of the special purpose foot.

### Step 1: Side Stitching

Position needle in fabric at point **A**. Lower the foot and stitch to end of marking. Leave needle in fabric at point **B**. Raise foot and pivot work on needle. Lower the foot. Take one stitch without changing stitch width setting, bringing work to point **C**.

### Step 2: Bar Tack

Adjust stitch width selector for bar tacks, and take about six stitches. Stop at point **D**.

### Step 3: Side Stitching

Readjust stitch width selector for side stitching. Complete work to point **E**. Leave needle in fabric.

### Step 4: Final Bar Tack

Adjust stitch width selector for bar tacks, and take about six stitches ending at point **F**.

### Step 5: Fastening Stitch

To secure stitching, move stitch width selector to  and take three stitches. Remove work, draw threads to underside, fasten, and trim. Cut opening for button with sharp scissors.

2

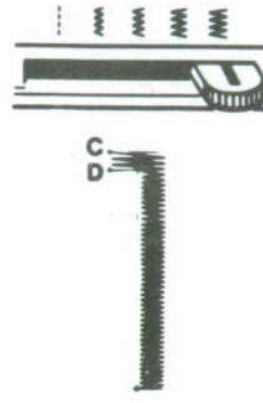

3

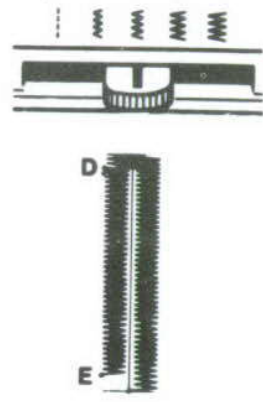

4

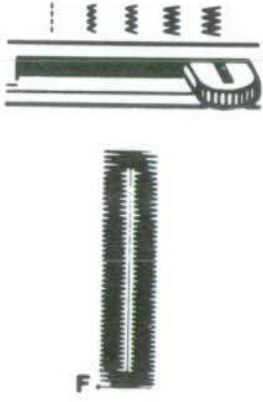

5

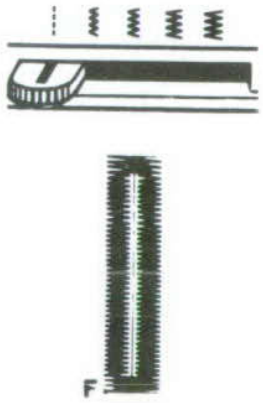

## Top Stitching

A practical simple way to accent the lines of dress or coat is to place one or more rows of stitching along collars, lapels, facing edges, pockets, sleeves, etc. For a tailored look, use rows of straight stitching. For decorative interest, use stitch pattern.

## Appliqué

Appliqué adds beauty and interest to clothes and household linens. Either contrasting or self fabric can be used effectively.

The stitch most commonly used appliquéing is the plain zig-zag stitch (see page 25), closely spaced to form a satin stitch. The width of this stitch can be varied to accommodate fabrics of different weaves and textures. Many of the other stitch patterns can be used to appliqué with decorative stitching.

To prepare for appliquéing, make a sample to help you decide which of the following two methods is more appropriate for your fabric and design.

- Mark design on piece of fabric to be appliqué'd.
- Cut out design leaving about 2cm (3/4") margin all around.
- Position the design.
- Baste it to the fabric.
- Attach special purpose foot.

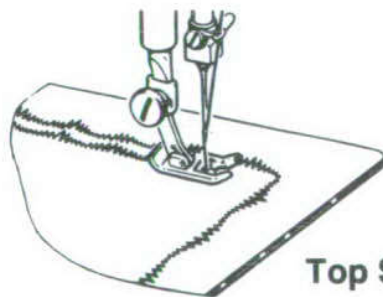

Top Stitching

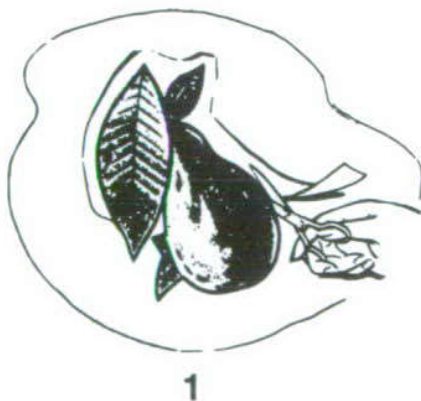

1

## Method No. 1

1. Select a stitch pattern suitable for the desired sewing application. Set stitch width selector for the desired width. For white patterns, set stitch length dial for satin stitching between 0 and 1; for green and blue/pink patterns, set it on position 4 (Green Blue/Pink).
2. Outline the entire design with appliqué' stitching.
3. Trim away excess fabric on the outer edges of the stitching. Remove basting.

## Method No. 2

1. Select a stitch pattern suitable for the desired sewing application.
2. Adjust stitch width selector for regular straight stitching and outline the entire design with a short stitch.
3. Trim raw edges to the stitching.
4. Adjust stitch width selector to desired width setting for appliqué' pattern, and set stitch length selector between 0 and 1 (or on position 4 (Green/Blue/Pink) if using one of the green or blue/pink Fjexi-Stitch patterns.)
5. Stitch, following and covering straight-stitch outline. This step will produce smooth overedged finish with no raw edges to be trimmed.

## Method No. 3

- Purchased motifs can be appliqué'd quickly and easily by using a straight or decorative stitch.



2





# Keeping up appearance

## Mending

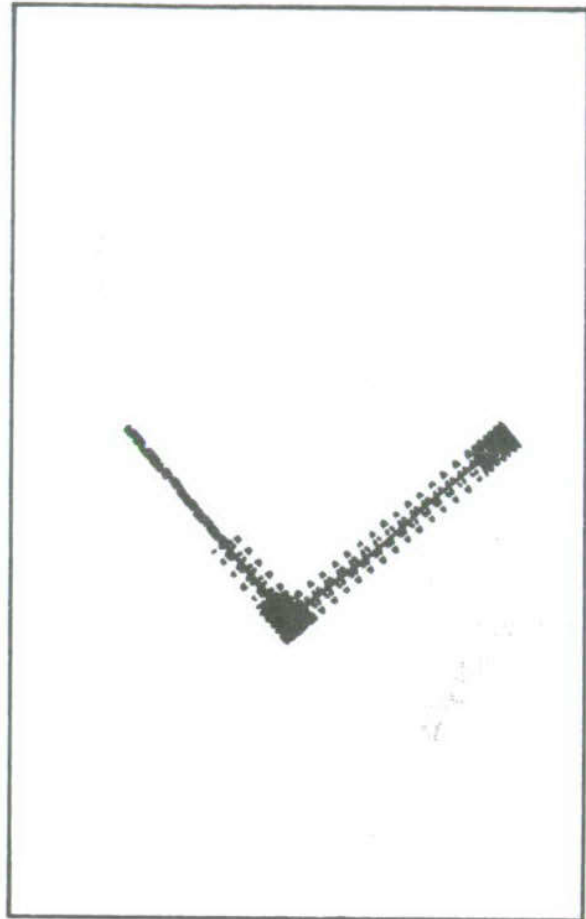
Many of the zig-zag stitch patterns are just as useful for mending as they are for creative sewing. The multi-stitch zig-zag yellow (  ) forms a firm, flexible bond for repairing tears and for replacing elastic. The plain zig-zag (yellow  ) is useful for making bar tacks to repair lingerie.



### 1. Tears

- Pattern Group:  Yellow
- Stitch Width: 
- Needle Position: 
- Stitch Length: About 1 or to suit fabric
- Zig-Zag Presser Foot
- Zig-Zag Needle Plate

1. Trim ragged edges.
2. Place underlay on the wrong side of tear for reinforcement. (It is best not to baste or pin the underlay since you will be bringing the edges of the tear together in the next step).
3. Stitch on the right side, bringing the edges of the tear together.
4. Shorten stitch length at ends and corners to give extra strength.
5. Trim underlay.

### 2. Bar Tacks

Use the plain zig-zag stitch (Yellow  ) at satin-stitch length between 0 and 1 for belt loops, pockets, zippers, shoulder straps, etc.



## Darning

You may choose to darn either with or without an embroidery hoop. When greater control is needed, an embroidery hoop is usually best.

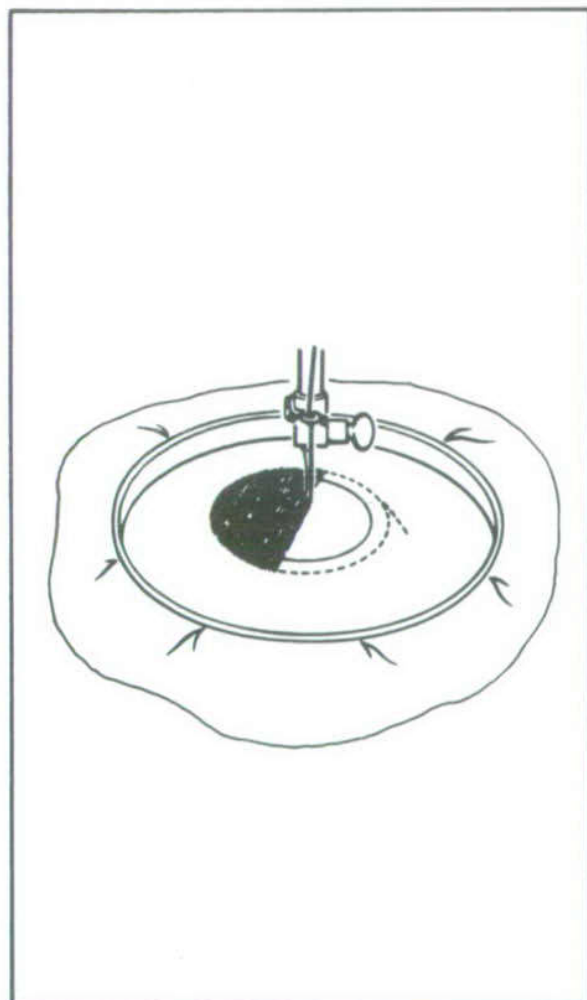
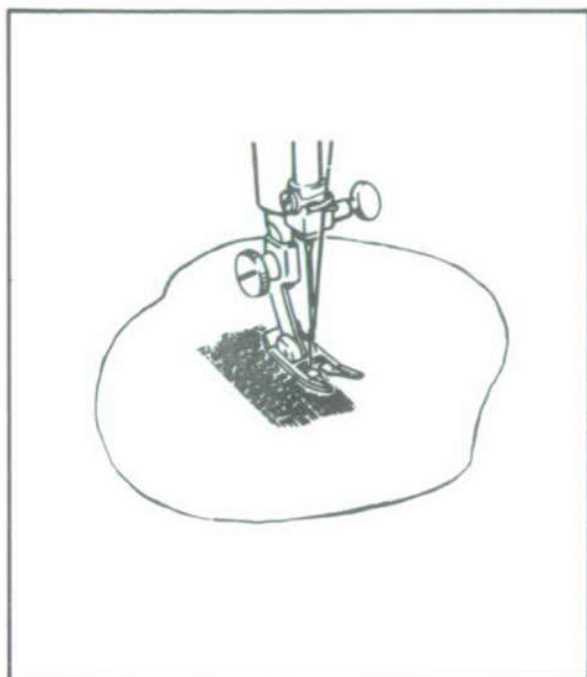









## Darning Without Embroidery Hoop

- Pattern Group:  (Yellow)
- Stitch Width:    
- Needle Position:   
- Stitch Length: 1.5
- Zig-Zag Presser Foot
- Zig-Zag Needle Plate

1. If area to be darned is open, baste an underlay in place.
2. Place area to be darned under the presser foot. Lower the presser foot and start stitching, alternately drawing the fabric toward you and gently pulling it away from you until area is filled with parallel lines of stitching.
3. For additional strength, cover area with crosswise lines of stitching.

## Darning With an Embroidery Hoop

- Pattern Group:  (Yellow)
- Stitch Width:    
- Needle Position:   
- Stitch Length: 0
- Presser Foot: None
- Snap-In Feed Cover

1. Trim ragged edges from area to be darned and center worn area in embroidery hoop designed for machine use.
2. Carefully position work under needle and lower presser bar to engage tension.
3. Hold needle thread loosely with left hand, turn hand wheel toward you, and draw bobbin thread up through fabric. Hold both thread ends and lower needle into fabric.
4. Reinforce the area to be darned with stitching 6mm (1/4") from the edge. Stitch across opening, moving hoop under needle at a slight angle from lower left to upper right. Keep lines of stitching closely spaced and even in length.
5. When opening is filled, cover area with crosswise lines of stitching.

# 8

## Free-Arm Sewing

Fabric handling, when sewing tubular and hard to reach garment areas, is simplified when you convert your sewing machine to free-arm sewing. Some of the sewing jobs for which you will find the free arm particularly useful are shown on this and the following pages. You will discover many more for yourself.

### *preparation*

To convert to free-arm sewing, simply press down on corner of *Flip & Sew* panel on sewing machine with heel of right hand.

To raise *Flip & Sew* panel, place hand under panel and lift up until it locks into place. A click will be heard when panel is locked in position.

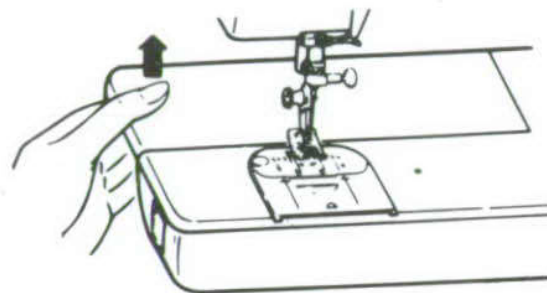
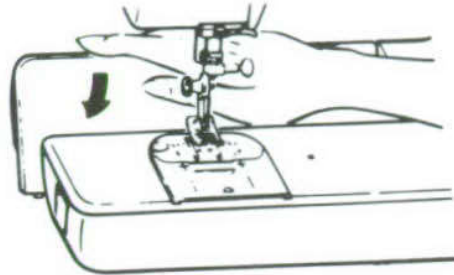

### *applications*

#### **Buttons**

Sewing buttons on a cuff or neckband is no longer a task when the free-arm surface is used. Cuffs slip around the sewing surface without being pulled out of shape, so you can see and handle the stitching area easily.

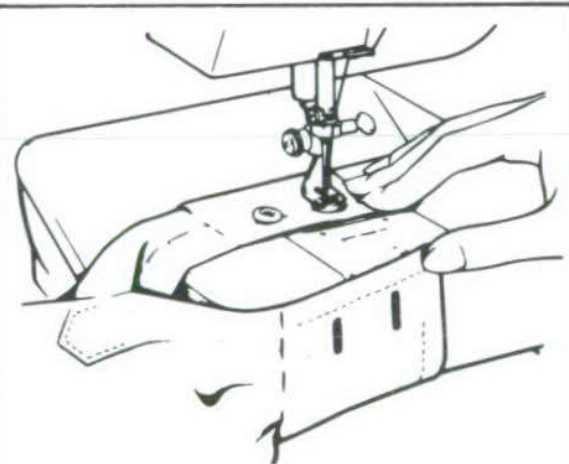

#### **Sleeves**

Free-arm sewing takes the difficulty out of topstitching a sleeve. The armhole rotates smoothly under the needle so that you can place stitching accurately. The extra control afforded by the free arm is especially helpful for topstitching flat-fell seams.

Badges, emblems and insignias can be attached to shirts and uniforms by slipping sleeve or hard-to-reach area over the sewing surface.

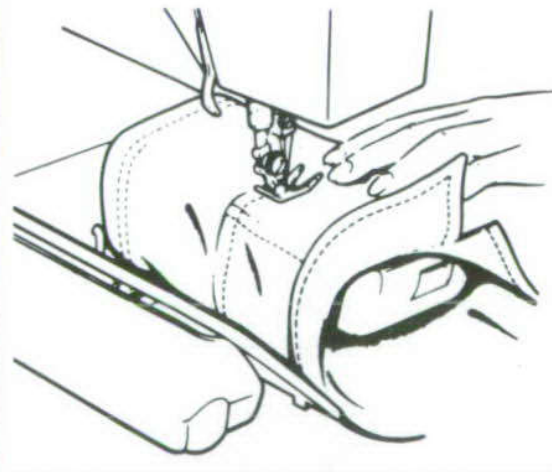

# 9

## Caring for Your Sewing Machine

### *cleaning and lubricating*

How often you will need to clean and lubricate the machine will depend on how often you use it and where you keep it. The following general guidelines assume that you will be sewing several times a week. But if you use your machine more frequently, lubricate it more often than the guidelines suggest.

**CAUTION:** Before cleaning and lubricating your machine, disconnect the power-line plug from your electrical outlet.

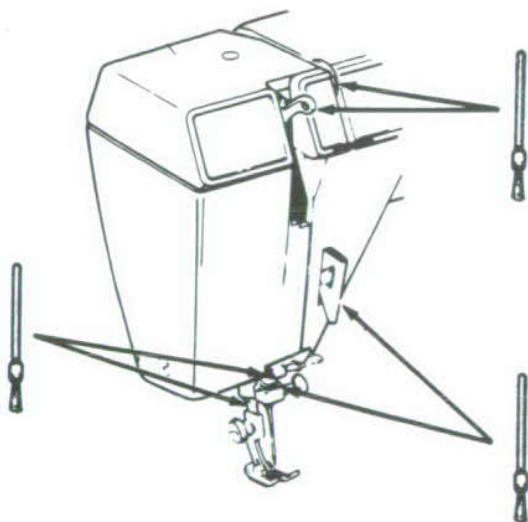

### *Every Few Weeks—*

Remove lint or fluff from exposed parts. With the lint brush, and a soft cloth, clean:

- Tension discs
- Take-up lever and thread guides
- Presser bar and needle bar

Remove needle plate, as instructed on page 7 and clean:

- Feed and hook area
- Bobbin case. Removal of lint from groove on outer edge of bobbin case is important. Lint accumulation could prevent machine from operating properly. (See next page for removal of bobbin case.)
- All machine surfaces (if necessary, dampen the cloth. Do not use detergents.)

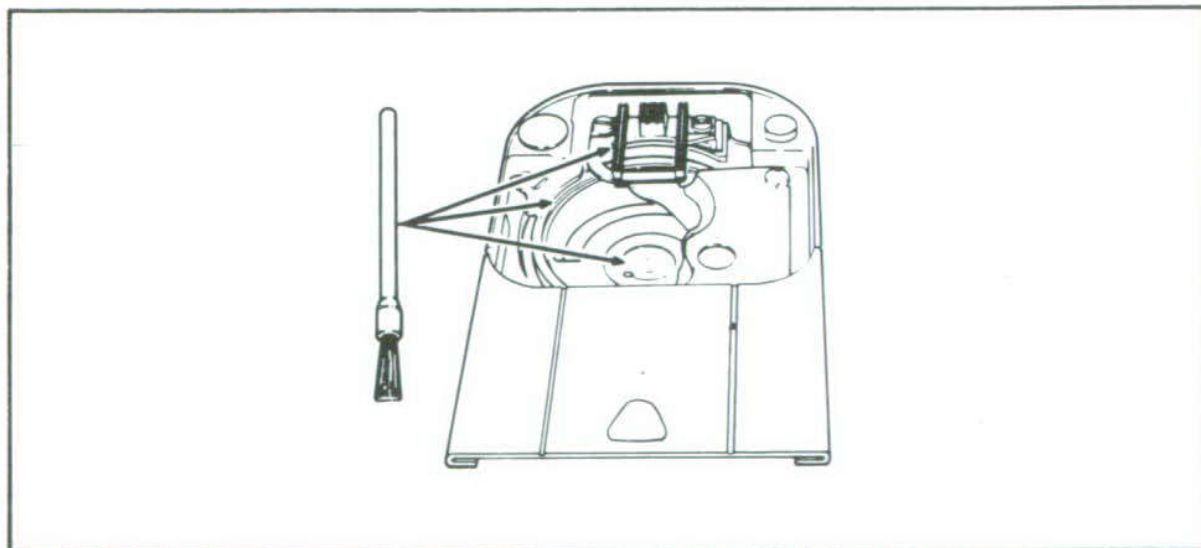

## Removing and replacing bobbin case

**Caution:** Before cleaning or adjusting the machine, remove plug from the socket outlet.

- Raise presser foot and needle.
- Open slide plate, remove bobbin and remove needle plate (see instruction on page 7).

### To remove bobbin case

- With a small screwdriver, turn bobbin case holder (1) to the rear as far as it will go.
- Lifting the left side of the bobbin case, slide it out from machine.

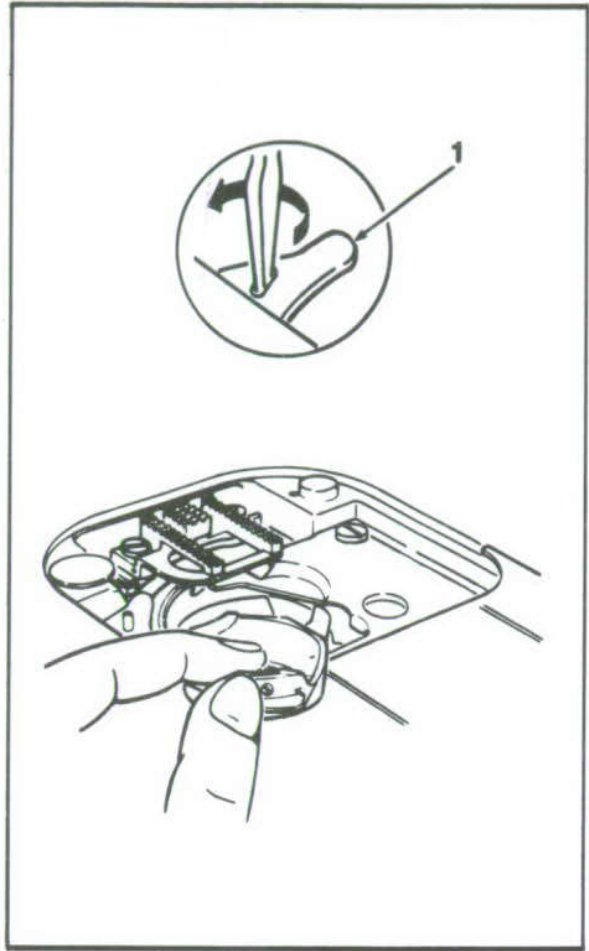

### To replace bobbin case

- Guide forked end (2) of bobbin case under feed (3).
- Draw rim of bobbin case under position plate (4). Be sure bobbin case is freely seated on hook race.
- Turn bobbin case holder (1) forward as far as it will go, locking bobbin case in place.

**Note:** Turn handwheel towards you to check to make sure it is properly replaced.

- Replace needle plate (see instruction on page 7).
- Insert bobbin and close slide plate.

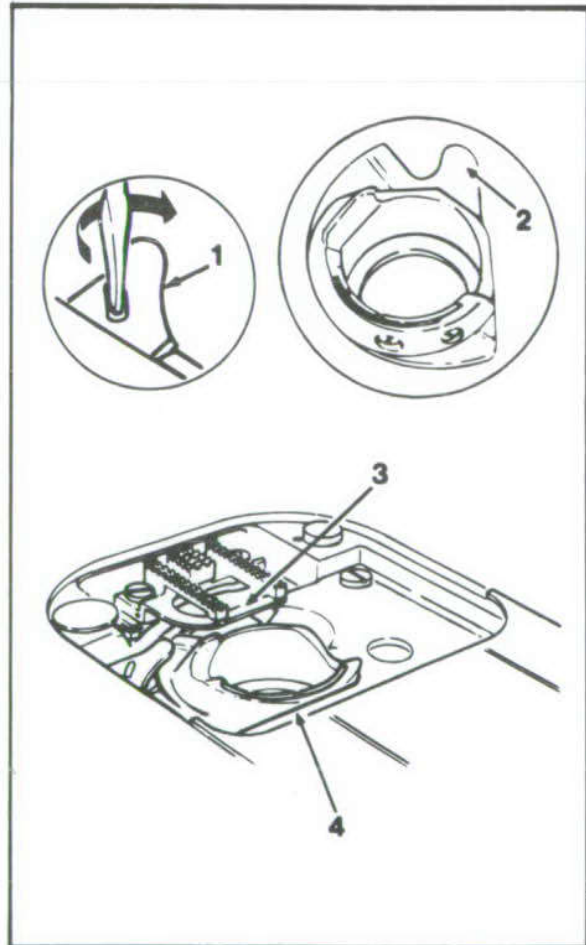

## every few months—

**Caution:** Before lubricating your machine, disconnect the power-line plug from your electrical outlet.

Lubricate parts behind the face plate, under the arm top cover, and bottom of machine.

- Apply a drop of oil (but no more than a drop) to all places indicated.

### To Remove Face Plate

- Lower presser-foot lifter.
- Loosen screw A.

- Remove face plate by grasping it around the bottom edge and pulling toward the left, then down and away from machine.

### To Replace Face Plate

- Replace face plate and tighten screw A.
- Return Presser-foot lifter to up position.

### To Remove Top Cover

- Loosen Screws B, C, D, and E.
- Lift top cover up and remove it from machine.

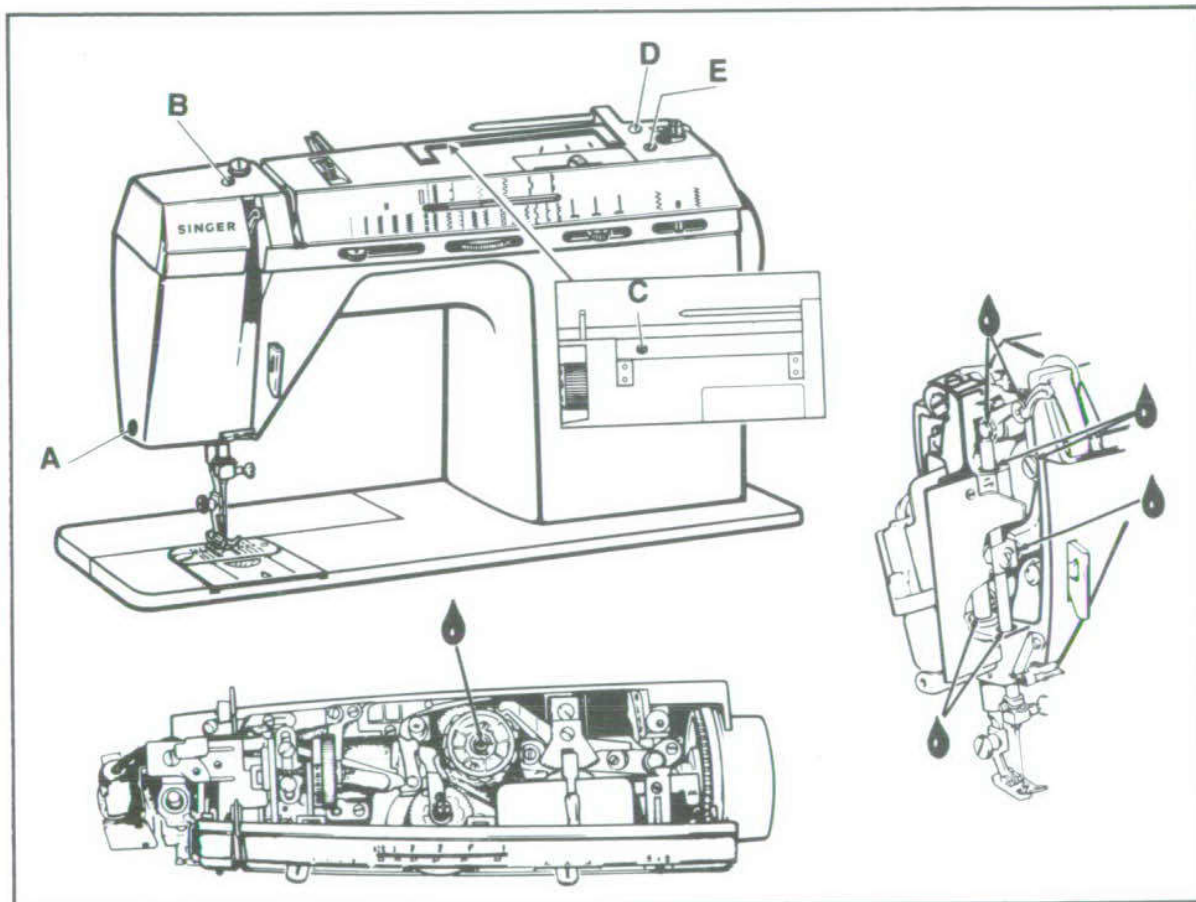

### To Remove Bottom Cover

- Loosen screws F, G, H and I.

- Remove bottom cover from machine.

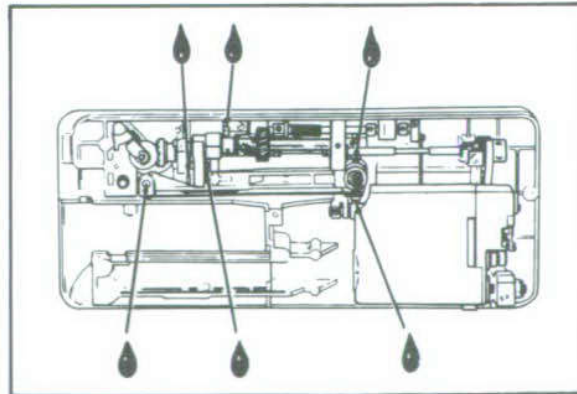
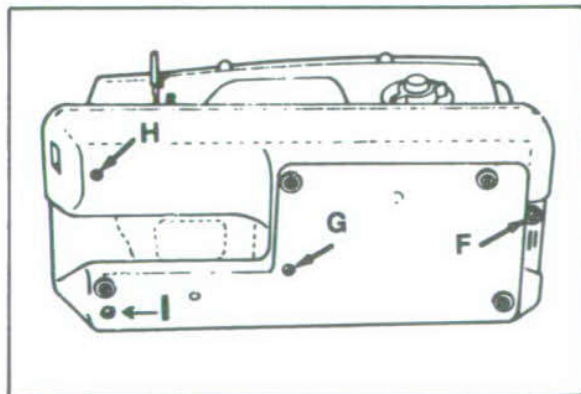

- Apply three drops of oil to all places indicated.
- Occasionally apply one drop of oil to all other rotating or moving machine connections to ensure freedom of movement.

After oiling, replace face plate and arm top cover. Sew a few lines of stitching on a scrap of material to remove excess oil.

**CAUTION:** Do not attempt to adjust the motor belt. Contact your nearest Service Centre should any adjustment be required.

## If Machine Is To Be Stored

- Disconnect power-line plug from electric outlet.
- Clean all exposed parts and area behind face plate.
- Swab all exposed metal parts and parts behind face plate with oil to protect against rust.

## Changing The Light Bulb

**CAUTION:** Disconnect the power-line plug from the socket outlet before changing light bulb.

This machine is designed to use a 15 watt maximum bayonet base bulb **only**.

Remove face plate, as instructed on page 51.

1. **Removing Bulb:** Press bulb into socket and at the same time turn bulb in direction shown to unlock bulb pin (do not attempt to unscrew the light bulb).
2. **Replacing Bulb:** Press new bulb into socket, with bulb pin entering slot of socket, and turn it in direction shown to lock bulb in position. Replace face plate.

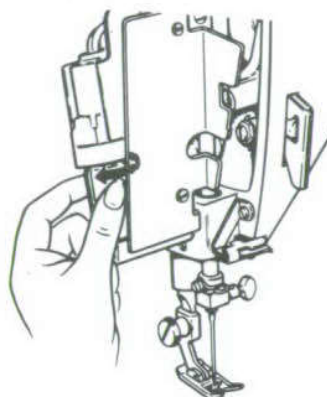

1

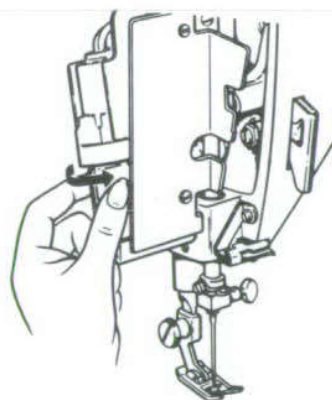

2

## Replacing The Slide Plate

You will not have any occasion to remove the slide plate. However, if it should accidentally become disengaged from the machine, it is easily replaced.

- Raise the presser foot and make sure needle is in its highest position.
- Place slide plate in slide way with the front edge close to, but not covering, the retaining spring (as shown).
- With a small screwdriver, lift each end of the spring **A** into each of the side grooves on the underside of the plate.
- Draw the plate gently toward you and fully engage the spring.
- Close slide plate.

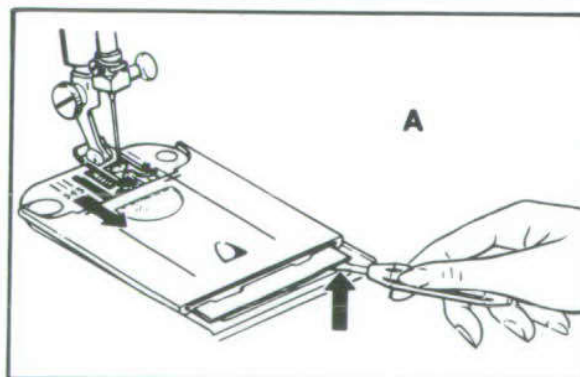

## hints for home service

### If needle breaks, make sure...

- Needle is straight, correct style for machine and proper size for thread being used.
- Needle is correctly inserted into machine.
- Stitch width and needle position selectors are correctly set for work being done.
- Stitch width setting does not exceed  setting when twin needle is used.
- Presser foot shank is securely fastened to presser bar.

### If needle thread breaks, make sure...

- Machine is threaded properly.
- Thread is unwinding freely from spool.
- Thread is free from irregularities.
- Needle is correct size for thread.
- Needle-thread tension is not too light.
- Bobbin and bobbin case are properly inserted in machine.
- Bobbin halves are evenly and securely screwed together.

### Remember to...

- Remove thread from bobbin before rewinding.
- Set combination stitch length and button-hole dial for regular stitching when not making buttonholes.





**8007/8019/8002**  
Part Number 356712-001 (REV. 3)

English